

DSP 9612 Flash Poll Modem User's Guide

Complements of ARC Electronics
800-926-0226 arc@arcelect.com
www.arcelect.com

Contents

CHAPTER 1 INTRODUCTION	5
FEATURES	6
APPLICATIONS	7
CHAPTER 2 INSTALLATION	9
UNPACKING YOUR HARDWARE.....	9
ADDITIONAL ITEMS YOU NEED	9
HARDWARE OVERVIEW	10
<i>Back View</i>	10
<i>Front View</i>	11
INSTALLATION SUMMARY	12
FINDING A SUITABLE LOCATION	12
CONFIGURING THE MODEM	13
<i>SW1 DIP Switch Settings</i>	14
<i>SW2 DIP Switch Settings</i>	17
<i>SW3 DIP Switch Settings</i>	21
CONNECTING TO A TRANSMISSION LINE.....	26
CONNECTING TO A VOLTAGE SOURCE.....	27
CONNECTING AN RS-232 DEVICE	28
LEDS	29
LOOPBACK CONTROL SWITCH.....	30
APPENDIX A TROUBLESHOOTING	31
PROBLEM SOLVING	31
APPENDIX B DIP SWITCH SUMMARY	33
APPENDIX C SPECIFICATIONS	35
GENERAL SPECIFICATIONS	35
MECHANICAL SPECIFICATIONS	36
INTERFACE CONNECTOR PIN ASSIGNMENTS.....	37
<i>RS-232 (DTE) Interface</i>	38
ENVIRONMENTAL SPECIFICATIONS.....	38
COMPLIANCES	39
APPENDIX D COMPLIANCES	41
APPENDIX E LIMITED PRODUCT WARRANTY	43
APPENDIX F RMA PROCEDURE	44

Contents

NOTES

Chapter 1

Introduction

Congratulations for purchasing the finest industrial-grade fast-poll modem available.

The DSP9612 (Flash Poll) modem is a 9600/4800/0-1800 bps modem designed for 4-wire, full-duplex or 2-wire, half-duplex operation over a voice-band leased line or private line. The modem is designed utilizing the latest digital-signal processing (DSP) technology to achieve high performance. The modem employs proprietary modulation and encoding scheme to achieve fast modem training time. The modem is also backward compatible with Bell 202 and ITU-T V.23 modems.

The DSP9612 modem is ideally suited for multi-point communication systems that require fast response time, short training time, and low throughput delay. The DSP9612 is the most technologically advanced modem on the market.

This User's Guide describes both the DSP9612FP (AC-powered) modem and the DSP9612-LV (DC-powered) modem. This manual is intended to let you get your modem "up and running" as quickly as possible. It contains all the information you need to configure and install your modem. It also contains troubleshooting information in the unlikely event you encounter a problem with your modem.

Introduction

Features

The DSP9612 modem is specifically designed for harsh environments found in utility substations and industrial facilities. Though functionally similar to commercial modems, the DSP9612 provides the following unique features that make it well suited for utility and industrial applications.

- ❖ Packaged in a rugged, compact enclosure for industrial applications.
- ❖ Leased-line interface protected with heavy-duty surge protection hardware (15KV).
- ❖ Requires no human intervention, making it ideal for unmanned locations.
- ❖ Works within an extended temperature range of -40°C to +85°C.
- ❖ Designed with coupling transformers for high-voltage isolation and common mode noise rejection in industrial and commercial environments.
- ❖ Operate over voice-band conditioned or unconditioned leased line and pilot wires.
- ❖ Accepts power from a wide range of AC and DC power supplies.
 - DSP9612FP: 85 to 265 VAC or 85 to 400 VDC
 - DSP9612-LV: 10 to 53 VDC
- ❖ Standard industrial connectors for data, analog, and power interfaces allow reliable interconnection to other industrial equipment.
- ❖ Asynchronous data rates (selectable) of 9600, 4800, and 0-1800 bps.
- ❖ Easily accessible DIP switches for user configuration and option selection.
- ❖ DB25 connector for RS-232/V.24 interface.
- ❖ Local analog, local digital, and remote digital loopback diagnostics.

Applications

The DSP9612 modem is designed for point-to-point and multipoint data communications. Figure 1-1 shows a typical multipoint configuration.

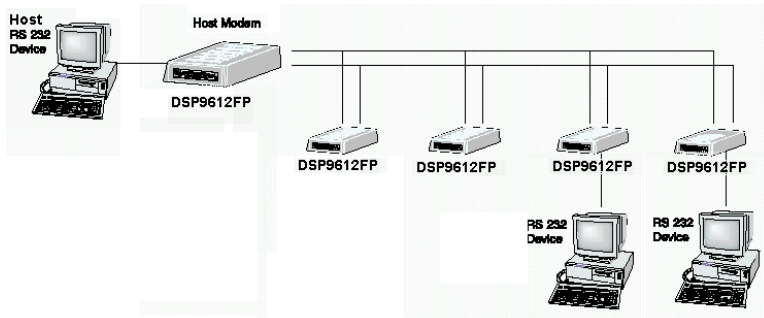

Figure 1-1. Network of Multipoint Configuration

There are a number of factors that can affect the network's and modem's operation and performance. These include:

- ❖ Operating speed
- ❖ 2-wire or 4-wire configuration
- ❖ Transmission line characteristics, noise, and line impairments
- ❖ Network configuration (point-to-point or multipoint)
- ❖ Number of nodes on the network

Introduction

NOTES

Chapter 2

Installation

This chapter describes how to install the modem.

Unpacking Your Hardware

Your package should include:

- ❖ At least one of the following DSP9612 modems:
 - Model DSP9612FP for 85 to 265 VAC
 - Model DSP9612-LV for 10 to 53 VDC
- ❖ A leased-line cable
- ❖ A shielded DC power cable (model DSP9612-LV modem only)
- ❖ This User's Guide

If your package contents are damaged or missing, please contact your place of purchase immediately.

Additional Items You Need

To use your modem, you need the following additional items:

- ❖ Two- or four-wire transmission line or leased line
- ❖ A DB25-F data cable for your Data Terminal Equipment (DTE) port

Installation

- ❖ A power supply that provides either:
 - 85 to 265 Volts AC, 50 to 60 Hz, single phase or 85 to 400 VDC (if you have the model DSP9612FP modem), or
 - 10 to 53 Volts DC (if you have the model DSP9612-LV modem)

Hardware Overview

Back View

Figures 2-1 and 2-2 show the back view of the two DSP9612 modem models. Starting from the left side, these views show:

- ❖ A 4-wire/2-wire configuration block. See page 26.
- ❖ A female, 25-pin RS-232 connector, for connecting a standard DTE (RTU). See page 28.
- ❖ A **POWER ON/OFF** switch.
- ❖ A power connector. See page 27.

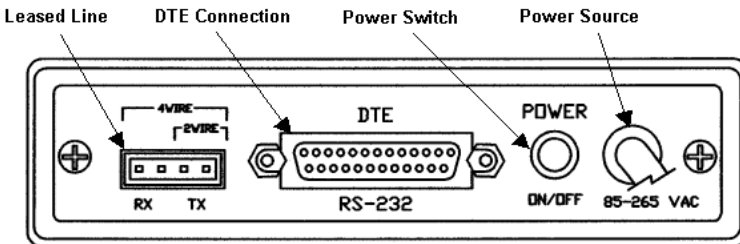

Figure 2-1. Back View of Model DSP9612FP Modem

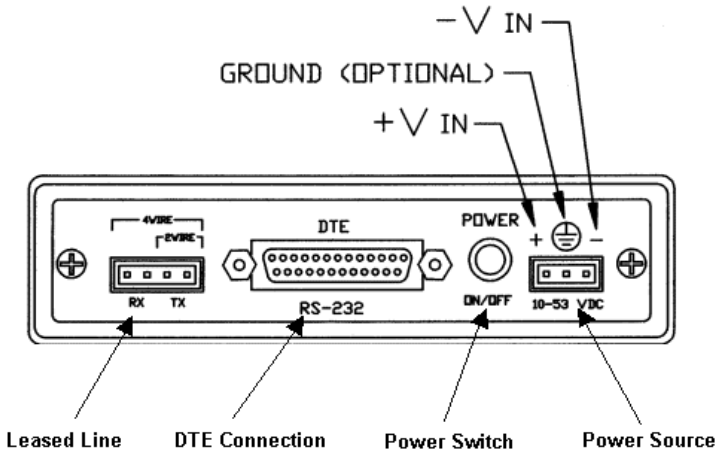

Figure 2-2. Back View of Model DSP9612-LV Modem

Front View

The Model DSP9612FP and Model 9612-LV modems have identical front panels. Figure 2-3 shows the front view of the modem. Starting from the left side, this view shows:

- ❖ A set of nine LEDs. See page 29.
- ❖ A loopback test switch. See page 30.



Figure 2-3. Front View of Modem

Installation

Installation Summary

The modem installation involves the following steps:

1. Finding a suitable location for the modem. See the section below.
2. Configuring the modem. See page 13.
3. Connecting to a transmission line. See page 25.
4. Connecting to a voltage source. See page 27.
5. Connecting a DTE device. See page 28.

Finding a Suitable Location

The location you select should provide easy access to the back panel communications interface(s) and front panel power interface. It should also let you view all the LEDs on the front panel.

Note: also offers a rack-mount version of this modem (Model DSP9612RM) as a plug-in module for the UDS RM16M Central Site Modem Rack. For more information, contact Corporation's Sales Department

Configuring the Modem

You configure the modem using the three sets of DIP switches on the bottom of the modem.



IMPORTANT

It is important to follow the three steps described below, in the order shown, to ensure that you configure your modem properly using the modem DIP switches:

1. Use DIP switch 3 (SW3) to configure the modem for your host DTE interface and network topology. Using SW3, you select the modem to operate in high-speed fast-poll or low-speed (FSK) mode.
 2. If you set SW3 for FSK mode in step 1, use DIP switch 2 (SW2) to configure the modem for either Bell 202T or ITU-T V.23 compatibility. Otherwise, you can use the modem in fallback mode.
 3. Use DIP switch 1 (SW1) to select the modem's transmitter output level and receiver dynamic range. The SW1 settings apply for both high-speed fast-poll and low-speed (FSK) modes.
-

Installation

SW1 DIP Switch Settings

SW1 is an 8-position DIP switch. Table 2-1 shows the modem switch settings for DIP switch SW1. A description of the SW1 switch settings follows the table.

Note: SW1 settings apply for both high-speed fast-poll and low-speed (FSK) modes

Table 2-1. Modem Switch Settings for DIP Switch SW1

Switches	Switch Settings	
	ON	OFF (Default)
SW1-1 – 1-4: Transmit Level (page 15)	(see Table 2-2 on page 15)	
SW1-5: Receiver Dynamic Range (page 16)	-10 to -43 dBm	+3 to -30 dBm
SW1-6: TX Cable Equalizer (page 16)	Enabled	Disabled
SW1-7: RX Cable Equalizer (page 16)	Enabled	Disabled
SW1-8: Anti-streaming (page 16)	Active	Inactive

Configuring the Modem

SW1-1 through SW1-4 – Transmit Level

Switches SW1-1 through SW1-4 adjust the modem's transmit level. Table 2-2 shows the transmit levels you can select using these switches.

Table 2-2. Transmit Levels

Transmit Level	SW1 through SW4 Switch Settings			
	SW1-1	SW1-2	SW1-3	SW1-4
0 dBm	OFF	OFF	OFF	OFF
-1 dBm	OFF	OFF	OFF	ON
-2 dBm	OFF	OFF	ON	OFF
-3 dBm	OFF	OFF	ON	ON
-4 dBm	OFF	ON	OFF	OFF
-5 dBm	OFF	ON	OFF	ON
-6 dBm	OFF	ON	ON	OFF
-7 dBm	OFF	ON	ON	ON
-8 dBm	ON	OFF	OFF	OFF
-9 dBm	ON	OFF	OFF	ON
-10 dBm	ON	OFF	ON	OFF
-11 dBm	ON	OFF	ON	ON
-12 dBm	ON	ON	OFF	OFF
-13 dBm	ON	ON	OFF	ON
-14 dBm	ON	ON	ON	OFF
+3 dBm	ON	ON	ON	ON

Installation

SW1-5 – Receiver Dynamic Range

SW1-5	ON = -10 to -43 dBm OFF = +3 to -30 dBm
-------	--

For a low receive signal level, set SW1-5 to ON (-43 dBm). For short distances or to select a strong receive signal, set SW1-5 to OFF.

SW1-6 and SW1-7 – Cable Equalizer (Fast-Poll Mode Only)

SW1-6	ON = Enable TX Cable Equalizer OFF = Disable TX Cable Equalizer
SW1-7	ON = Enable RX Cable Equalizer OFF = Disable RX Cable Equalizer

To improve or extend the modem's polling performance, use the fixed Compromise Cable Equalizer when polling on long metallic circuits. The cable equalizer is active only when the modem is in fast-poll mode (SW3-1 set to OFF).

SW1-8 – Anti-streaming

SW1-8	ON = Anti-streaming active OFF = Anti-stream inactive
-------	--

Typically, anti-streaming is used in multi-point applications to prevent a malfunctioning slave modem from occupying the line indefinitely. When anti-streaming is active, the modem can transmit data for a maximum of 27 seconds before the transmitter turns off automatically. The modem then looks for an ON-to-OFF Request To Send (RTS) transition before proceeding with normal operation. Anti-streaming can be selected in either high-speed or low-speed mode.

SW2 DIP Switch Settings

SW2 is an 8-position DIP switch. Table 2-3 shows the modem switch settings for DIP switch SW2. A description of the SW2 switch settings follows the table.

Table 2-3. Modem Switch Settings for DIP Switch SW2

Switches	Switch Settings	
	ON	OFF (Default)
SW2-1: FSK Mode (page 18)	V.23	Bell 202
SW2-2: Receiver Squelch (page 18) (valid for FSK mode, 2-wire half-duplex operation only)	Turnaround Squelch (Bell 202): 8ms Turnaround Squelch (V.23): 150ms	Turnaround Squelch (Bell 202): 0ms Turnaround Squelch (V.23): 0ms
SW2-3: FSK Soft Carrier (page 19)	Disabled	Enabled
SW2-4 and SW2-5: FSK RTS-CTS Delay (page 19)	(see Table 2-4)	
SW2-6: FSK CD Delay (page 20)	23ms	6ms
SW2-7: Remote Loopback (page 20)	Enabled	Disabled
SW2-8: Reserved (Test Only) (page 20)	Test	Normal

Installation

SW2-1 — FSK Mode

SW2-1	ON = ITU-T V.23 mode OFF = Bell 202 mode
-------	---

The modem has two FSK modes:

- ❖ Bell 202, which supports data rates from 0 to 1800 bps
- ❖ ITU-T V.23, which supports data rates from 0 to 1200 bps

SW2-1 configures the modem for either of these FSK modes. Setting SW2-1 to ON selects ITU-T V.23 mode. In this mode, the modem complies with ITU-T (CCITT) recommendation V.23 with the following parameters:

- ❖ Mode 2 modulation only
- ❖ No backward channel
- ❖ No provisions for disablement of echo suppressors
- ❖ DTR (circuit 108) is ignored

Setting SW2-1 OFF selects Bell 202 mode.

SW2-2 — Receiver Squelch (FSK Mode 2-Wire Half-Duplex Only)

SW2-2	ON = 8ms for Bell 202, 150ms for ITU-T V.23 OFF = 0ms
-------	--

SW2-2 configures the turnaround squelch delay and is valid when the following are active:

- ❖ FSK mode (SW3-1 ON)
- ❖ 2-wire half-duplex operation (SW3-7 ON)

Setting this switch to OFF configures the modem to enable its receiver immediately after the Request To Send (RTS) signal is turned off. When this switch is set to OFF and the modem is configured for 2-

Configuring the Modem

wire, half-duplex mode (SW3-7 ON), the modem squelches the receiver after RTS is turned off to prevent far-end echoes from causing data errors. The duration that the modem squelches the receiver is either:

- ❖ 8 milliseconds if the modem is configured for Bell 202 mode (SW2-1 OFF)
- ❖ 150 milliseconds if the modem is configured for ITU-T V.23 mode (SW2-1 ON)

SW2-3 — FSK Soft Carrier (Bell 202 FSK Mode Only)

SW2-3	ON = None
	OFF = 8ms

SW2-3 controls the soft carrier and is valid for Bell 202 FSK mode only (SW2-1 set to OFF). Setting this switch to OFF configures the modem to transmit a 900 Hz soft carrier to the remote modem for 8 milliseconds after RTS is turned off. Setting this switch to ON prevents the modem from transmitting a soft carrier after RTS is turned off.

SW2-4 and SW2-5 — RTS-CTS Delay (Bell 202 Mode Only)

Switches SW2-4 and SW2-5 determine the duration of the RTS-CTS delay in Bell 202 mode. Table 2-4 shows how to set these switches to select the appropriate setting.

Table 2-4. RTS-CTS Delay Settings in Bell 202 Mode

To Select a Delay of...	Set SW2-4 to...	And Set SW2-5 to...
8ms	OFF	OFF
33ms	OFF	ON
59ms	ON	OFF
219ms	ON	ON

Installation

When the modem is configured for V.23 operation (SW2-1 ON), the RTS-CTS delay is fixed at 33 ms.

SW2-6 — FSK CD Delay (Bell 202 Mode Only)

SW2-6	ON = 23ms OFF = 6ms
-------	------------------------

SW2-6 selects the FSK CD delay and is valid when Bell 202 mode is active (SW2-1 OFF). Setting SW2-6 ON configures the modem to turn on CD 23 milliseconds after it detects a valid carrier signal. Setting this switch to OFF configures the modem to turn on CD 6 milliseconds after it detects a valid carrier signal.

This switch setting is deactivated when the modem is configured for V.23 mode (SW2-1 ON) and a delay of 18 milliseconds is used instead.

SW2-7 — Remote Loopback

SW2-7	ON = Loopback enabled OFF = Loopback disabled
-------	--

During instances of channel noise, the modem may mistaken a received preamble as a request to go into remote digital loopback. Setting SW2-7 to OFF prevents the modem from participating in a remote digital loopback with another modem. SW2-7 does not prevent the modem from sending a remote digital loopback request to a remote modem.

SW2-8 – Reserved (Test Only)

SW2-8	Must be OFF
-------	-------------

SW2-8 must be in the OFF position for normal operation.

SW3 DIP Switch Settings

SW3 is a 10-position DIP switch. Table 2-5 shows the modem switch settings for DIP switch SW3. A description of the SW3 switch settings follows the table.

Table 2-5. Modem Switch Settings for DIP Switch SW3

Switches	Switch Settings	
	ON	OFF (Default)
SW3-1: Fast Poll/FSK (page 22)	FSK	Fast Poll Auto-Rate
SW3-2: Data Rate (page 23)	4800 bps	9600 bps
SW3-3: Async Character (page 23)	11 bits	10 bits
SW3-4: Auto RTS (page 23)	Enabled	Disabled
SW3-5: Transmitter Termination (page 24)	Switched by RTS	600 Ω
SW3-6: Reserved (Test Only) (page 24)	Test	Normal
SW3-7: 2- or 4-wire (page 24)	2-wire, half-duplex	4-wire, full-duplex
SW3-8: Carrier Control (page 25)	Constant	Switched
SW3-9: Rx Termination (page 25)	600 Ω	High Rx Impedance
SW3-10: Signal Ground and Earth Ground Option (page 25)	Connected	Separated

Installation

SW3-1 – Fast Poll Auto Rate/FSK

SW3-1 ON = Low-Speed Mode (FSK)
OFF = High-Speed Mode (Fast Poll)

The modem has two operating modes:

- ❖ FSK mode, which supports data rates from 0 to 1800 bps.
- ❖ Fast-poll mode, which supports data rates of 4800 and 9600 bps.

SW3-1, along with the Data Rate Selector (DRS) pin on the modem's RS-232 connector, configures the modem for either FSK or fast-poll mode. Table 2-6 shows how SW3-1 and the DRS signal configure the modem for these operating modes.

Table 2-6. Modem Operating Mode

To Select...	Set SW3-1 to...	And the DRS Signal...
Fast-poll mode	OFF	Is not connected or is set HIGH
FSK mode	OFF	Is set LOW
FSK mode	ON	Doesn't care

You should use the DRS signal in RTS control mode. It does not work in either constant carrier mode (SW3-8 set to ON) or in the auto-RTS mode (SW3-4 set to ON). The DRS signal is only sampled when the transmitter is idle (when not sending a preamble, data, or a turn-off sequence).

Note that DRS controls both the transmitter and receiver. If DRS changes states while the modem is receiving a preamble, data, or a turn-off sequence, the state of the receiver is unknown until the carrier drops and a new preamble is received. We recommend that DRS does not change states until both the local and remote modems' transmitters are in the idle state. When they are, both the local and remote modems' DRS signal should change states.

Configuring the Modem

SW3-2 – Data Rate (Fast-Poll Mode Only)

SW3-2	ON = 4800 bps OFF = 9600 bps
-------	---------------------------------

SW3-2 configures the modem speed. When the modem is in high-speed fast-poll mode (SW3-1 OFF), setting SW3-2 ON selects 4800 bps, while setting SW3-2 OFF selects 9600 bps.

SW3-3 – Async Character (Fast-Poll Mode Only)

SW3-3	ON = 11 bits OFF = 10 bits
-------	-------------------------------

Switch SW3-3 selects whether the async character is 10 or 11 bits long. When the modem is in high-speed fast-poll mode (SW3-1 OFF), setting SW3-3 ON selects an 11-bit async characters, while setting SW3-3 OFF selects a 10-bit async character.

SW3-4 – Auto RTS (Fast-Poll Mode Only)

SW3-4	ON = Enable Auto RTS OFF = Disable Auto RTS
-------	--

For data terminals that do not support hardware RTS, set SW3-4 to ON to enable auto RTS mode. In this mode, TXD is detected at the modem and an internal RTS signal is turned ON. After training completes, the TXD is transmitted to the remote modem. The transmitter turns off if no TXD is detected after 1 character length of idle time. Auto RTS is used in fast-poll mode only (SW3-1 set to OFF).

Installation

SW3-5 – Transmitter Termination

SW3-5	ON = Switched by RTS OFF = 600 Ω
-------	--

SW3-5 is used for multi-point configuration networks. When multiple modems are connected on the same metallic circuit:

- ❖ The transmitter termination should be of high impedance if the modem is not transmitting.
- ❖ The transmitter is only terminated with 600 ohms when RTS is asserted.

This configuration should be used for all slave modems to prevent the transmitting modem from being unnecessarily burdened. To select this configuration, set SW3-5 ON on the slave modems.

If you use the modem with transmission lines that are transformer-coupled or with an impedance-isolated network (such as a transformer bridge), set SW3-5 OFF for proper operation.

SW3-6 – Reserved (Test Only)

SW3-6	Must be OFF
-------	-------------

SW3-6 must be in the OFF position for normal operation.

SW3-7 – 2-/4-Wire Operation

SW3-7	ON = 2-Wire, Half-Duplex Mode OFF = 4-Wire, Full-Duplex Mode
-------	---

SW3-7 configures the modem for 4-wire full-duplex or 2-wire half-duplex operation.

SW3-8 – Carrier Control

SW3-8	ON = Constant OFF = Switched
-------	---------------------------------

SW3-8 selects either constant or switched carrier. Constant carrier allows DTEs, such as asynchronous dumb terminals or RTUs, to operate with modems, without the input RTS signal. When constant carrier mode is enabled (SW3-8 set to ON), the modem forces the transmit carrier active and the RTS-CTS delay is minimum (<0.5 ms.).

You can use constant carrier in 4-wire, point-to-point or multi-point applications (from master to slave modems).

In switched-carrier mode (SW3-8 set to OFF), the RTS/CTS delay is active.

SW3-9 – RX Termination

SW3-9	ON = Enable Rx Termination OFF = Disable Rx Termination
-------	--

SW3-9 selects whether RX termination is enabled for a modem. If you set this switch ON, the receiver is terminated with 600 Ω . If you set this switch OFF, the receiver is not terminated.

SW3-10 – Grounding Option

SW3-10	ON = Signal Ground and Earth Ground are Connected OFF = Signal Ground and Earth Ground are Separated
--------	---

Installation

Connecting to a Transmission Line

The modem has a transmission line interface that can be configured for 2- or 4-wire, analog connection, where one pair is used to transmit data (Tx and Tx) and one pair is used to receive data (Rx and Rx). Table 2-7 shows the pin numbers and corresponding signals for the modem. Figure 2-4 shows the transmission line interface.

Note: For communication to occur, the Rx line of one modem must connect to the Tx line of the other modem. The modem's Tx/Rx pair are non-polarized.

Note: The modem does not support leased-line operations with DC current.

Table 2-7. Transmission Line Connector Pin Assignments

This Pin Number...	Corresponds to This Signal...
1	Rx
2	Rx
3	Tx
4	Tx

Connecting to a Voltage Source

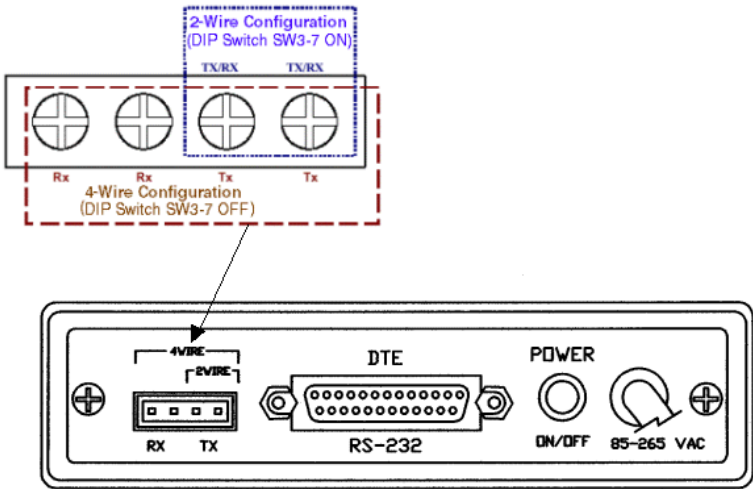

Figure 2-4. Transmission Line Interface

Connecting to a Voltage Source

The back panel of the modem provides the power interface. For convenience, the modems can be powered from the following power sources:

- ❖ Model DSP9612FP (AC version): 85 to 265 Volts AC, 50 to 60 Hz, single phase or 85 to 400 VDC
- ❖ Model DSP9612-LV (DC version): 10 to 53 Volts DC. The model DSP9612-LV comes with a shielded power cord for making this connection.

Figure 2-1 on page 10 shows the connection to the Model DSP9612FP's power interface. Figure 2-2 on page 11 shows the connection to the Model DSP9612-LV's power interface.

Installation



WARNING

Before you connect a voltage source, observe the following power supply voltage guidelines. Otherwise, you will void your warranty if the wrong voltage is applied.

- ❖ Be sure the voltage source is within the permitted ranges shown above. Otherwise, your modem and any attached devices may be damaged.
 - ❖ Customer-supplied cables must be suitable for the site environmental conditions.
 - ❖ Screw terminals on the power interface accept 24 to 16 AWG. However, surge protection is guaranteed only if the ground wire is greater than 18 AWG and if there is a solidly earthed ground connection.
 - ❖ Be sure the power source is not controlled by a wall switch, which can be inadvertently turned off, shutting off power to the modem.
-

Connecting an RS-232 Device

The modem back panel provides a female, 25-pin RS-232 connector that accepts an attached RS-232 device (see Figure 2-1 on page 10). This connector accepts a standard connection to a DTE (RTU) that conforms to the pin assignments shown under “RS-232 (DTE) Interface” on page 38.

LEDs

The front panel of the modem provides the LEDs shown in Table 2-8.

Table 2-8. Modem LEDs

LED	Color	Description
PWR	Green	Power Input
RTS	Yellow	Request To Send
CTS	Yellow	Clear To Send
TD	Yellow	Transmit Data
RD	Yellow	Receive Data
CD	Yellow	Carrier Detect
MR	Yellow	Modem Ready
ALB	Red*	Analog Loopback
DLB	Red*	Digital Loopback
* When the modem is in remote loopback, both the ALB and DLB LEDs go ON.		

Installation

Loopback Control Switch

The front panel of the modem has a push button for initiating the following loopback diagnostic tests:

- ❖ Local analog loopback — started by pressing the button one time.
- ❖ Local digital loopback — started by pressing the button two times.
- ❖ Remote digital loopback — set the local modem's RTS signal to low. Then press the remote modem's diagnostics button three times and raise the local modem's RTS signal to start the test. The **ALB** and **DLB** LEDs go ON when the modem is in remote digital loopback. This test is only available in fast-poll mode only.

Figure 2-4 illustrates these three diagnostics.

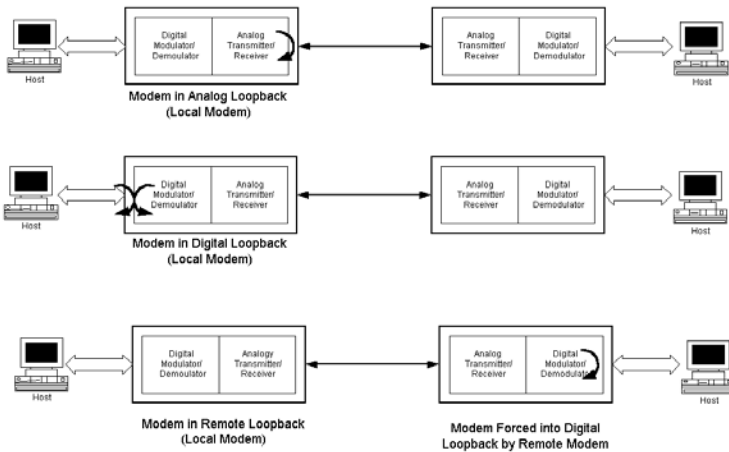

Figure 2-4. Loopback Diagnostics

Appendix A

Troubleshooting

In the event you encounter a problem using your modem, refer to the troubleshooting information in this appendix.



IMPORTANT

If you encounter a problem with your modem, be sure the switches on the bottom of the modem are set to the appropriate positions. If a switch is halfway between an on and off setting, the modem will not operate properly.

Problem Solving

Table A-1 offers troubleshooting solutions for modem problems.

Table A-1. Troubleshooting Suggestions

If...	Perform These Procedures...
Modem does not respond to the attached DTE and the all LEDs are off.	Check the power supply input for your specific model (see page 27).
Modem does not receive data, and the DCD and RxD LEDs are off.	The receive line pair may be disconnected from the modem. Make sure the transmission line connection to the modem is accurate and secure. The receive signal level may be below the CD threshold. Set SW1-5 ON to see whether configuring the modem for a -43 dBm threshold resolves the

Troubleshooting

Table A-1. Troubleshooting Suggestions

If...	Perform These Procedures...
	problem.
The RTS , CTS , and TxD LEDs do not blink.	The attached terminal or DTE may not be sending data to the modem. Verify that data is being transmitted. If data is being transmitted, make sure the RS-232 cable is sound and securely connected to the modem and terminal or DTE.

Appendix B

DIP Switch Summary

Switches	Switch Settings	
	ON	OFF (Default)
SW1-1 – 1-4: Transmit Level (page 15)	(see Table 2-2 on page 15)	
SW1-5: Receiver Dynamic Range (page 16)	-10 to -43 dBm	+3 to -30 dBm
SW1-6: TX Cable Equalizer (page 16)	Enabled	Disabled
SW1-7: RX Cable Equalizer (page 16)	Enabled	Disabled
SW1-8: Anti-streaming (page 16)	Active	Inactive

SW2-1: FSK Mode (page 18)	V.23	Bell 202
SW2-2: Receiver Squelch (page 18) (valid for FSK mode, 2-wire half-duplex operation only)	Turnaround Squelch (Bell 202): 8ms Turnaround Squelch (V.23): 150ms	Turnaround Squelch (Bell 202): 0ms Turnaround Squelch (V.23): 0ms
SW2-3: FSK Soft Carrier (page 19)	Disabled	Enabled
SW2-4 and SW2-5: FSK RTS-CTS Delay (page 19)	(see Table 2-4)	
SW2-6: FSK CD Delay (page 20)	23ms	6ms
SW2-7: Remote Loopback (page 20)	Enabled	Disabled
SW2-8: Reserved (Test Only) (page 20)	Test	Normal

DIP Switch Summary

Switches	Switch Settings	
	ON	OFF (Default)
SW3-1: Fast Poll/FSK (page 22)	FSK	Fast Poll Auto-Rate
SW3-2: Data Rate (page 23)	4800 bps	9600 bps
SW3-3: Async Character (page 23)	11 bits	10 bits
SW3-4: Auto RTS (page 23)	Enabled	Disabled
SW3-5: Transmitter Termination (page 24)	Switched by RTS	600 Ω
SW3-6: Reserved (Test Only) (page 24)	Test	Normal
SW3-7: 2- or 4-wire (page 24)	2-wire, half-duplex	4-wire, full-duplex
SW3-8: Carrier Control (page 25)	Constant	Switched
SW3-9: Rx Termination (page 25)	600 Ω	High Rx Impedance
SW3-10: Signal Ground and Earth Ground Option (page 25)	Connected	Separated

Appendix C

Specifications

General Specifications

Data rate:	9600, 4800, or 0-1800 bps asynchronous
Data format:	8 or 9 data bits with 1 or more stop bits
DTE interface:	EIA RS-232 or V.24 compatible
Line conditions:	TELCO Voice band 4- or 2-wire leased line, conditioned or unconditioned Private metallic circuits up to 9.5 miles (24 AWG) without cable equalizer. Up to 15.0 miles (24 AWG) with TX and RX cable equalizer
Operating modes:	2-wire half-duplex or 4-wire full-duplex
Modulation:	High-speed fast poll – proprietary FSK, Bell 202T or V.23 compatible <ul style="list-style-type: none">• Mark = 1200 Hz (1300 Hz, V.23)• Space = 2200 Hz (2100 Hz, V.23)• Soft Carrier = 900 Hz (Bell 202T only)
Equalizer:	Automatic, adaptive
RTS-CTS Delay:	23 ms. (fast poll) 8, 33, 59, or 219 ms (Bell 202) 33 ms (V.23)

Specifications

Receiver

dynamic range: 0 to -30 dBm or -10 to -43 dBm

Operating

temperature: -40°C to +85°C

Power supply:

Wide range switching power supply:

- DSP9612FP (AC version): 85 to 265Volts AC, 50/60 Hz, single phase or 85 to 400 VDC
- DSP9612-LV (DC version):10 to 53 Volts DC

Surge protection: Leased line, up to 15KV

Carrier control: Constant or switched, DIP switch selectable

Carrier loss

recovery: Train on Data

Throughput delay: Less than 10 milliseconds for fast polling.

Auto RTS: Support DTE without hardware RTS (high speed only)

Anti-Streaming: 27-second timer to prevent transmitter lock-up network

Mechanical Specifications

Enclosure: Aluminum with removable front and rear panels

Dimensions: 5.70" wide x 8.30" long x 1.50" high

Weight: 1.9 lbs.

Interface connectors

Leased line: 4-position screw terminal.

Data Terminal

Equipment: DB-25 female connector

Interface Connector Pin Assignments

Leased Line Terminal Block Pin Assignments

This Pin Number...	Corresponds to This Signal...
1	Rx
2	Rx
3	Tx
4	Tx

Back-to-Back Connection to a Second Modem

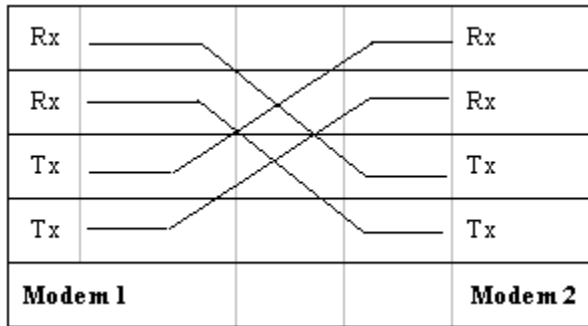

Specifications

RS-232 (DTE) Interface

Signal Name	Modem Input/Output	DB25 Pin	Description
Earth GND	—	1	Earth Ground
TXD	Input	2	Transmit Data
RXD	Output	3	Receive Data
RTS	Input	4	Request To Send
CTS	Output	5	Clear To Send
DSR	Output	6	Data Set Ready (Modem Ready)
SG	—	7	Signal Ground
DCD	Output	8	Data Carrier Detected
DRS	Input	23	Data Rate Select

Environmental Specifications

Operating temperature: -40 to + 85° C

Storage temperature: -40 to +125° C

Operating humidity: 5 to 95 %, non-condensing.

Line Isolation: 3750 V RMS

Surge protection: Leased line up to 15K VA

Compliances

The modem is designed to meet the following agency requirements:

EMI/RFI:

FCC part 15 for Class A computing device

Industry Canada. (Emissions)

Specifications

NOTES

Appendix D

Compliances

This device complies with Part 15A of the FCC Rules. Operation is subject to the following two conditions: (1) this device may not cause harmful interference, and (2) this device must accept any interference received, including interference that may cause undesired operation.

This equipment has been tested and found to comply with the limits for a Class A digital device, pursuant to Part 15A of the FCC Rules. These limits are designed to provide reasonable protection against harmful interference in a residential installation. This equipment generates, uses, and can radiate radio frequency energy and, if not installed and used in accordance with the instructions, may cause harmful interference to radio communications. However, there is no guarantee that interference will not occur in a particular installation. If this equipment does cause harmful interference to radio or television reception, which can be determined by turning the equipment off and on, the user is encouraged to try to correct the interference by one or more of the following measures:

- ❖ Reorient or relocate the receiving antenna.
- ❖ Increase the separation between the equipment and the receiver.
- ❖ Connect the equipment to an outlet on a circuit other than the one to which the receiver is connected.
- ❖ Consult the dealer or an experienced radio/TV technician for help.

If none of these actions resolves the problem, consult your distributor or an experienced radio/television technician for additional suggestions.

Additionally, Section 15.838, paragraph d), of the FCC Rules and Regulations states: “Where special accessories, such as shielded cables, are required in order to meet FCC regulations, shielded cables must be used with this equipment. Operation with non-approved equipment or unshielded cables is likely to result in interference to radio and TV reception. The user is cautioned that changes and modifications to this equipment without the approval of the manufacturer could void the user’s authority to operate this equipment.

Compliances

Department of Canada Statement

This Class A digital apparatus meets all requirements of the Canadian Interference-Causing Equipment Regulations.

Cet appareil numérique de la classe A respecte toutes les exigences du Règlement sur le matériel brouilleur du Canada.

Appendix E

Limited Product Warranty

workmanship and perform to applicable published specifications for a period of 18 months from the date of delivery to Customer or 12 months from placement into service, whichever occurs first. The liability of hereunder shall be limited to replacing or repairing, at its option, any defective Products which are returned F.O.B., facility, Lake Forest, California (or, at option refunding the purchase price of such products). In no case are Products to be returned without first obtaining permission and a customer return order number from In no event shall be liable for any consequential or incidental damages.

Products which have been subject to abuse, misuse, accident, alteration, neglect, unauthorized repair or installation are not covered by the warranty. shall make the final determination as to the existence and cause of any alleged defect. No liability is assumed for expendable items such as lamps and fuses. No warranty is made with respect to custom products or Products produced to Customer's specifications except as specifically stated in writing by in the agreement for such custom products.

This warranty is the only warranty made by with respect to the goods delivered hereunder, and may be modified or amended only by a written instrument signed by a duly authorized officer or and accepted by Customer.

This warranty and limitation extends to customer and to users of the product and is in lieu of all warranties with respect to the product whether express, implied, or statutory, including without limitation the implied warranties of merchantability and fitness for a particular purpose.

Appendix F

RMA Procedure

Return Merchandise Authorization (RMA) Procedure

Before returning any product, an RMA number must be obtained.

Before asking for an RMA number, ascertain that the product was purchased from If you bought the product from a Distributor or Systems Integrator, the product should be returned to that vendor.

The most convenient method to obtain an RMA number for a product purchased from is to send an email to [Information required must](#) include

Your Company Name, address, the actual address that we would use to return the product to you. Please include any Mail Stop or specific delivery information. The City, State, and zip code are all required. Your phone and FAX numbers. Your email address.

If the above information is on your letterhead, that format is acceptable.

For each item you wish to return: List the product model number, usually found on the serial number tag, the serial number for each item you wish to return, a description of the problem you are encountering, and the cause of the problem (if known).

A product support specialist may call to verify that the product is properly installed or may ask you to perform tests to insure that the product has actually failed.

After review of the problem, an RMA number will be assigned, you will be notified by email or FAX.

The product must be properly packed and returned to:

The RMA number must be legibly displayed on the shipping carton.

No RMA's will be issued without a product review, will not be responsible for any product returned without an RMA number.

In the near future the RMA form will be available on our Web site
Fill in all blanks and click on the "Submit" button.

If you think the product may be out of warranty, include a method of payment for repairs, either a Purchase Order number, or Credit card number, Card Holder Name, Date of Expiration on the RMA request. Repairs currently require 5 – 10 working days, and are returned UPS second day air.

