

**NS-108 8-Port Switch**  
**10/100 Fast Ethernet Switch**  
**Installation Guide**

## Table of Contents

<b>1. Introduction.....</b>	<b>3</b>
1.1 Features.....	5
1.2 Specifications.....	6
<b>2 Installing the Switch.....</b>	<b>7</b>
2.1 Unpacking.....	7
2.2 Checking Power.....	7
<b>3. Making Network Connections.....</b>	<b>8</b>
3.1 Network Switched Ports.....	8
3.2 UTP Cable.....	9
3.3 UTP Connections.....	10
3.4 Operating Mode.....	11
<b>4. LED Indicators.....</b>	<b>12</b>
4.1 LED Panel.....	12
4.2 Interpretation.....	12

# 1. Introduction

---

NS-108 Industrial Switches are DIN-Rail mounting and designed for industrial environments. Their rugged packaging and protected circuitry keep them working under conditions that may cause office-grade units to fail.

Industrial Ethernet applications are demanding - This 8-port Fast Ethernet switch become the basic unit of the whole Ethernet network. It is also the good companion of our I-7188EX and I-8000 Ethernet embedded controller. The NS-108 comes with multiple ports, each capable of transmitting or receiving information simultaneously at full wire speed to control and allocate the network bandwidth. Besides that, the NS-108 Industrial Ethernet Switch automatically determines and remembers where an Ethernet device is located and routes the messages only through the appropriate port. This minimizes network loading and enables true deterministic communications over Ethernet

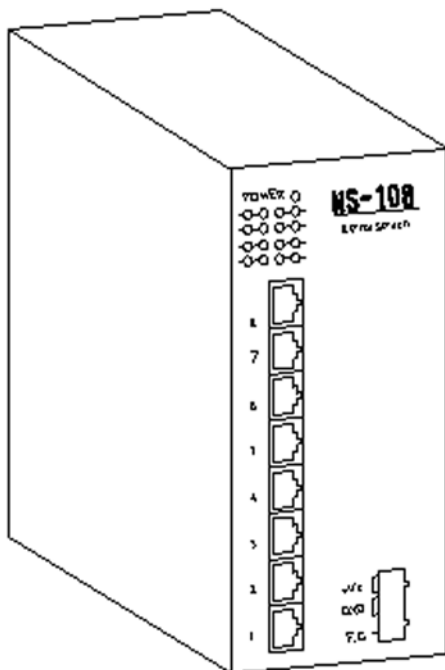

Front Panel

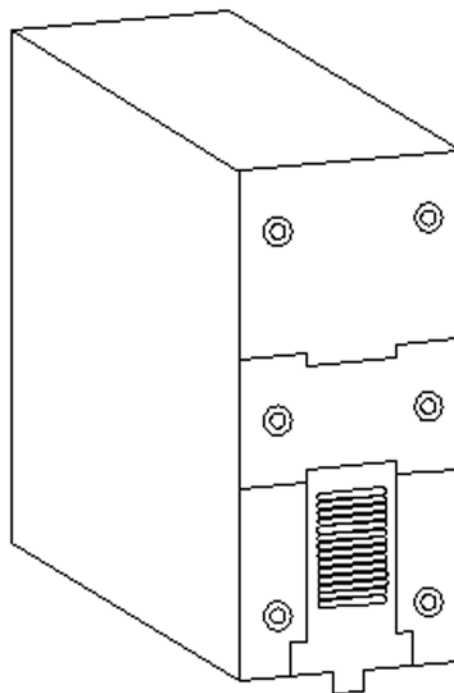

Rear Panel

The key features of this switch unit are:

- **Optimized Bandwidth :** Combining eight 10/100Mbps-based Fast Ethernet switched ports, the switch delivers a high network bandwidth for your Fast Ethernet network
- **Easy Migration :** With 10BASE-T support on each port, the switch provides a non-disruptive and smooth migration path from Ethernet to a Fast Ethernet network. automatic address learning , address aging and address migration.
- **Easy Installation :** With the functions of auto-speed-sensing and auto-negotiation on each port, the switch supports plug-and-play installation which eliminates configuration problems.

## 1.1 Features

- IEEE 802.3 10BASE-T, IEEE802.3u 100BASE-TX and IEEE 802.3x flow control standards
- Eight 10/100BASE-TX auto-negotiation switched ports for flexible connections to desktop PCs, servers and Ethernet hubs.
- The 10/100BASE-TX switched support :
  - Auto speed sensing for 100Mbps or 10Mbps connection
  - Auto Configuration with auto-negotiation devices
  - Full-duplex and Half-duplex operation
  - Broadcast storm protection
- Self learning for active MAC addresses
- Store and forward switching to ensure only good packets are forwarded
- Forwarding and filtering at full wire speed
- Supports IEEE 802.3x flow control for full-duplex operation
- Supports back-pressure flow control for half-duplex operation
- Comprehensive LED indicators provide quick, easy to read port and switch information

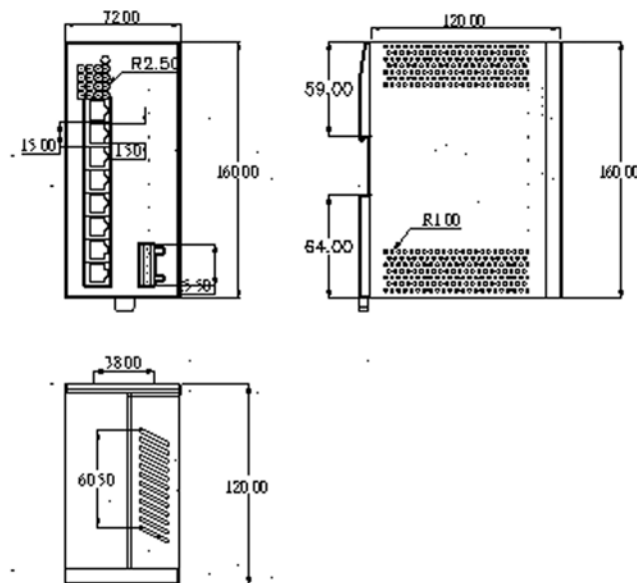

## 1.2 Specifications

<b>Port 1-8</b>	10BASE-T/100BASE-TX connectivity One MDI-X RJ-45 / MDI RJ-45 jack
<b>Cables</b>	10BASE-T Cat.3,4,5 UTP cable (100meters max.) 100BASE-TX Cat.5 UTP cable (100meters max.)
<b>LED indicators</b>	Power status 10/100Link/Activity/Speed/Duplex/Collision status per port
<b>Filtering rate</b>	14,880pps for Ethernet(100BASE-T) 148,800pps for Fast Ethernet(100BASE-TX)
<b>Forwarding rate</b>	14,880pps for Ethernet(10BASE-T) 148,800pps for Fast Ethernet(100BASE-TX)
<b>Filtering address</b>	Multicast/Broadcast/Unicast address 1K MAC address per unit
<b>RAM buffers</b>	64KB
<b>Environment</b>	Temperature            0 <sup>0</sup> C to 60 <sup>0</sup> C Relative humidity    10% to 90% non-condensing
<b>Dimensions</b>	70mm x 160mm x 120mm
<b>Power Requirement</b>	+10 ~ +30 VDC
<b>Power Consumption</b>	5 W

## 2. Installing the Switch

---

### 2.1 Unpacking

Check to see that you have everything before you start the installation.

- Installation guide
- The switch unit

### 2.2 Checking Power

**Since NS-108 consume 5 W power, make sure your power supply can meet this demand.**

Input DC voltage range: 10~30V

The screw terminal of the DC power input is located on the front of the switch as shown below :

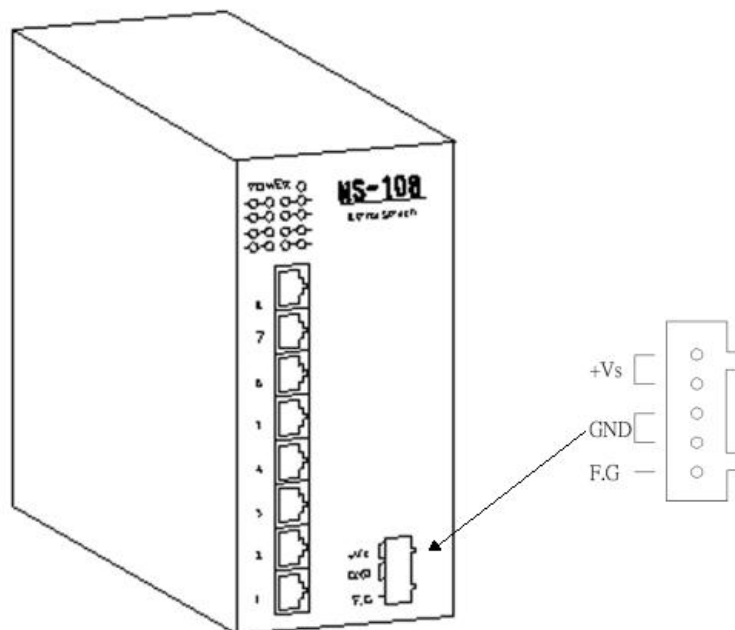

## 3.0 Making Network Connections

### 3.1 Network Switched Ports

There are eight ports on the switch for connection to eight LAN segments. Each segment is an independent shared network in one collision-domain.

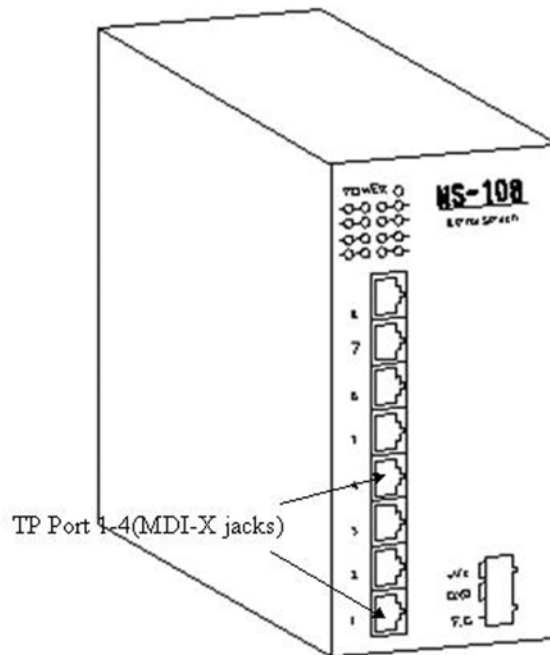

- **Eight 10/100BASE-TX switched ports**

Each port consists of one RJ-45 connector and is used for connection to either a 10BASE-T or 100BASE-TX device. The RJ-45 connectors are fixed MDI-X jacks, which are designed with internal crossover function. It allows a connection to an end station using straight-through UTP cable.

RJ-45	Pin Definition	Port 1-8
MDI-X	1 RX+ 2 RX- 3 TX+ 6 TX- 4,5,7,8 NC	✓
MDI	1 TX+ 2 TX- 3 RX+ 6 RX- 4,5,7,8 NC	✓



### 3.2 UTP Cable

When making a connection to another device using straight-through UTP cable, make sure MDI-X to MDI connection rule is followed. The following figure illustrates the pin assignments of a straight-through UTP and a crossover UTP cable :

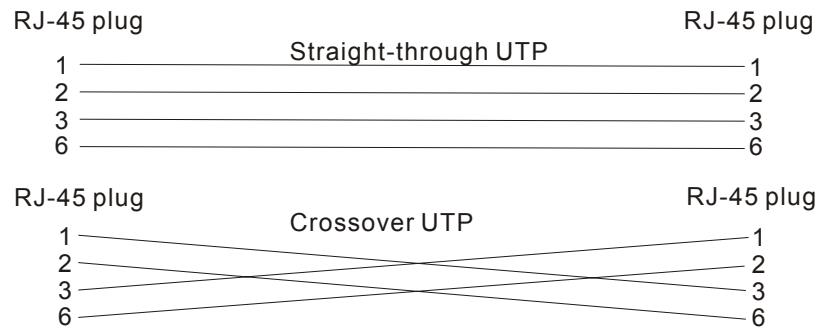

It is suggested to use straight-through UTP cables for all UTP connections. The maximum length and UTP cable categories used for the connections to a 10BASE-T device and 100BASE-TX device are :

<b>CONNECTED DEVICE UTP CABLE USED &amp; MAXIMUM LENGTH</b>	
10BASE-T device	Cat. 3,4,5 UTP(100meters)
100BASE-TX device	Cat. 5 UTP(100meters)

### 3.3 UTP Connections

The NS-108 switch can support connections to the following devices:

- 10BASE-T network cards
- 10/100BASE-TX network cards
- 10BASE-T hub ports
- 100BASE-TX hub ports
- 10/100BASE-TX dual speed hub ports
- 10/100BASE-TX switch ports
- Ethernet devices
- Ethernet Embedded controller, such as I-7188EX, I-7188EA, I-8430, I-8431, I-8830, I-8831, I-8437, I-8837, I-8438, I-8838

The following figure shows some connection examples and also specifies the maximum distance of each connections:

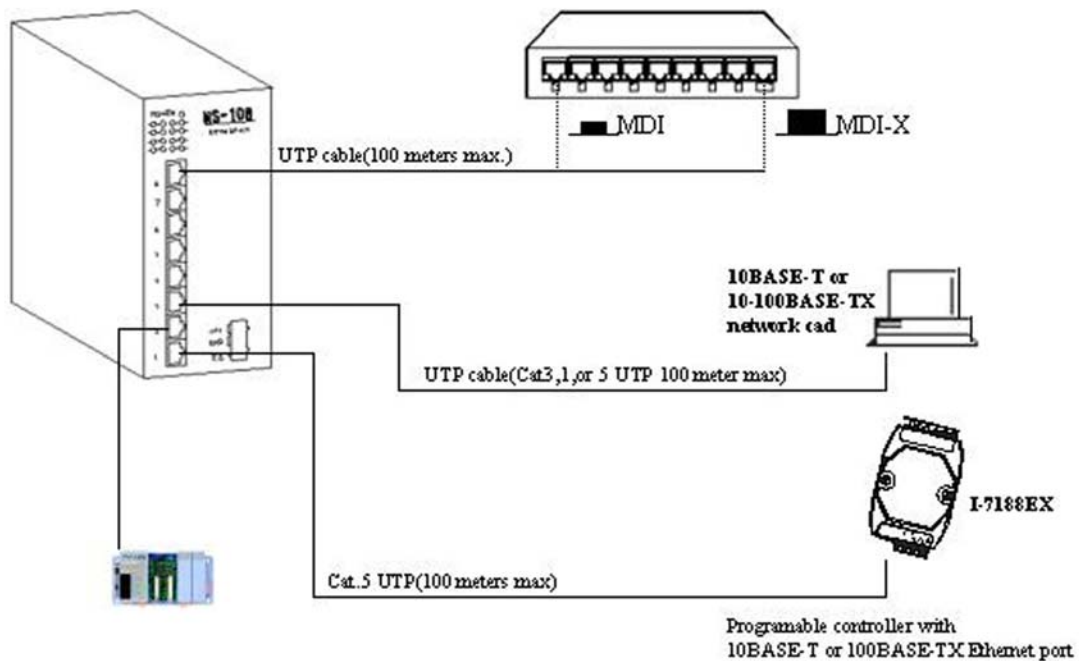

### 3.4 Operating Mode

All switched ports are designed as auto-negotiation capable switched ports. Each port can determine the speed and duplex type used automatically through an auto-negotiation process with the remote connected auto-negotiation device. The auto-negotiation process is performed when the connection is made.

When connecting to a non-auto-negotiation device, each TP port also features the capability to auto-sense the connection speed.

The following table lists the operation mode used for the switched port when it connects to different devices. The operating mode includes the connection speed and duplex type.

<b>Connected Device</b>	<b>Operation Mode Used</b>
10BASE-T hub	10Mbps, half-duplex
100BASE-TX hub	100Mbps, half-duplex
Auto-negotiation device	Auto-negotiation <sup>*2</sup>
Non-auto <sup>*1</sup> half-duplex device	Auto-speed-sensing <sup>*3</sup> , half-duplex
Non-auto full-duplex device	Not supported

\*1 Non-auto : non-auto-negotiation

\*2 determined through auto-negotiation process

\*3 speed is determined by auto-sensing function

Most of 10BASE-T hubs and 100BASE-TX hubs are non-auto-negotiation devices and operate on half-duplex mode.

## 4. LED Indicators

---

### 4.1 LED Panel

The NS-108 switch provides comprehensive LED indicators for diagnosing and monitoring the operation of the unit as shown below :

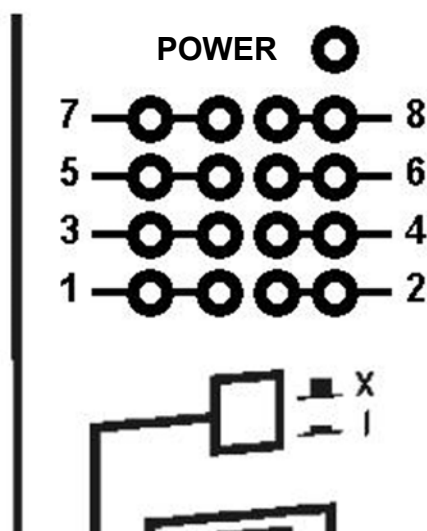

### 4.2 Interpretation

Each port has three LEDs to indicate the port status including cable link, connection speed, activity, collision and duplex mode. Every port has identical interpretations for the LED display as follows:

LED NAME	STATE	INDICATION
PWR	On	The power to the switch is on.
PWR	Off	The power to the switch is off
Link/Act.	On	An active link is established.
Link/Act.	Blink	Tx or Rx activities.
Link/Act.	Off	There is no active link established.
10/100M	On	100Mbps link is established.
10/100M	Off	10Mbps link is established.