

TC1540

RS-232/RS-422/RS-485 FIBER OPTIC MODEM User's Manual

MODEL: _____

S/N: _____

DATE: _____

Notice!

Although every effort has been made to insure that this manual is current and accurate as of date of publication, no guarantee is given or implied that this document is error free or accurate with regard to any specification. TC Communications, Inc. reserves the right to change or modify the contents of this manual at any time without prior notification.

Table Of Contents

Chapter 1 - Overview	3
Description	3
DIP Switch Functions	5
LED Functions	5
Theory of 2 and 4-Wire RS-485 Operation	6
RS-485 Transition Timer Setup	7
RS-422 & RS-485 Termination Resistor	7
Pin Assignments and Connection	8
Transmission Distances (typical)	10
Launch Power & Sensitivity	10
Power Supply	10
Chapter 2 - Installation	11
Unpacking the Unit	11
Equipment Location	11
Installation Procedure Summary	11
Installation Example (for 2-wire RS-485 application)	12
Chapter 3 - Troubleshooting	14
General	14
Power On LEDs Flash	14
Alarm Conditions	14
Optic Cable Types	14
Calculating the Loss on the Fiber	14
Chapter 4 - Bench Tests	16
General	16
Testing Considerations	16
Bench Test With Built-In Signal Generator	16
Optic Loopback Bench Test	17
Local Electrical Loopback Bench Test	18
Remote Loopback Bench Test	19
Chapter 5 - Specifications	20
Chapter 6 - Appendix	21
Return Policy	21
Warranty	21

Chapter 1 - Overview

Description

The TC1540 Fiber Optic Modem interconnects a host controller with RTUs (Remote Terminal Units) with RS-232, RS-422 or RS-485 (2 or 4-wire) interfaces for point-to-point communication. TC1540T is the extended temperature version of TC1540. Asynchronous data rates up to 500 Kbps are supported (contact factory for higher data rate requirements). The RS-422/485 interface is standard; RS-232 interfaces are optional. Different interfaces can be interconnected.

The TC1540 is equipped with eight DIP switches and eight LED indicators (on the top cover) to facilitate installation and troubleshooting.

Optic options include 850nm and 1310nm Multimode wavelengths; 1310nm or 1550nm Single Mode wavelengths. The optional optic redundancy feature can provide maximum reliability for crucial applications.

Fiber optic connectors are ST; FC is optional (ST is a trademark of AT&T). The electrical connector is a removable terminal blocks. Power is 9V to 12V DC at 250mA. Optional power sources are also available (see Chapter 5 - Specifications).

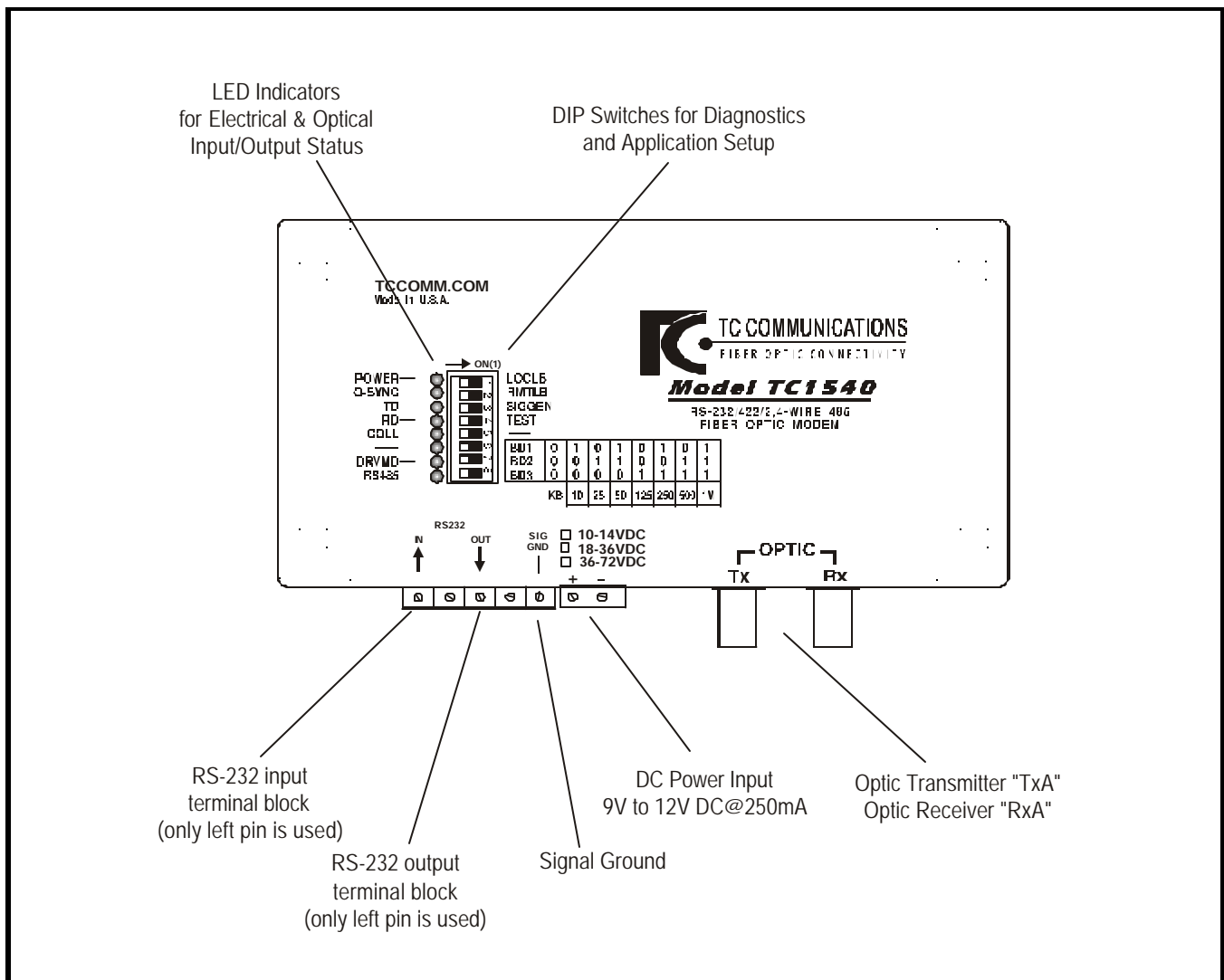

Figure 1. TC1540 with RS-232 Interface

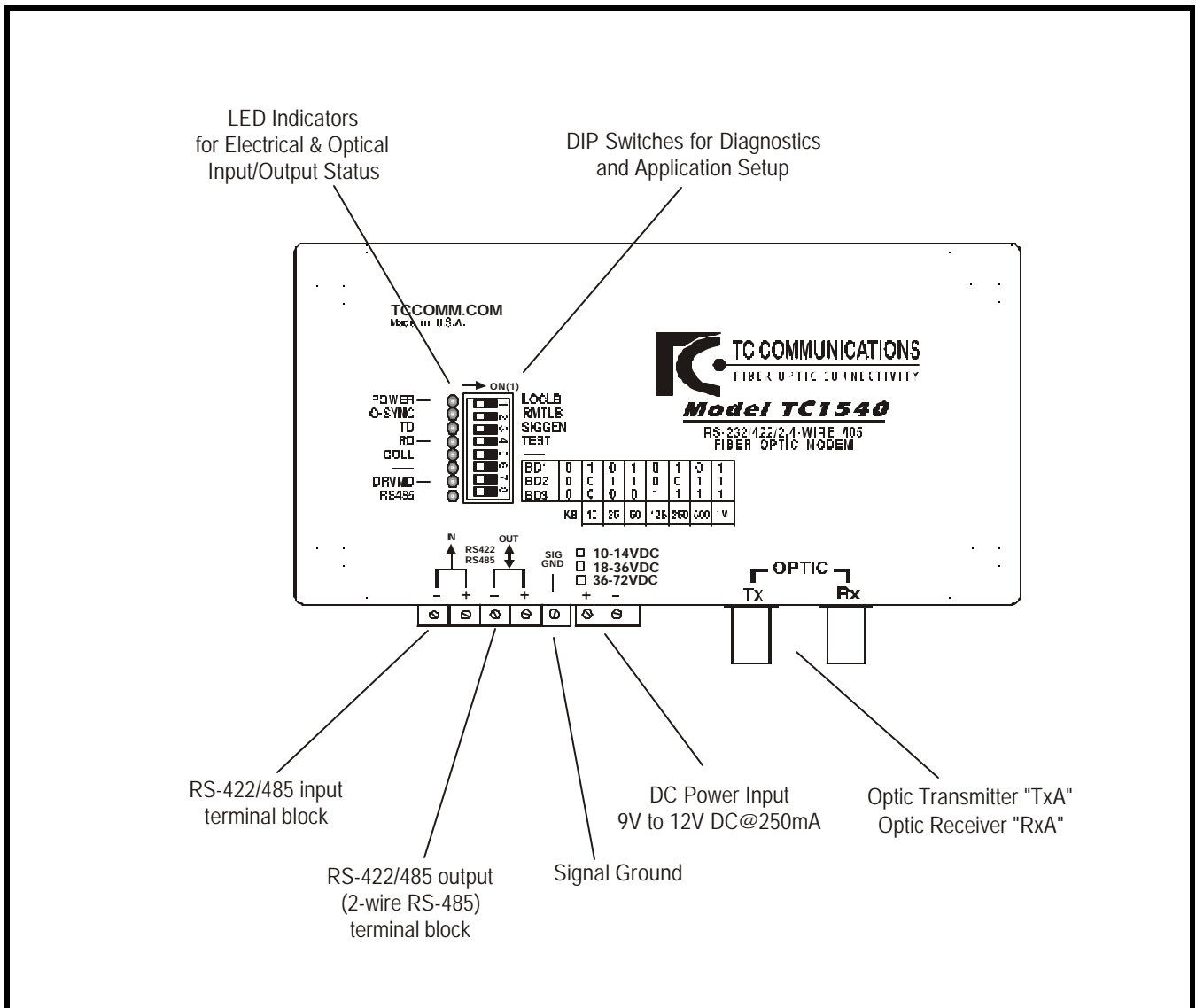

Figure 2. TC1540 with RS-422/RS-485 Interface

DIP Switch Functions

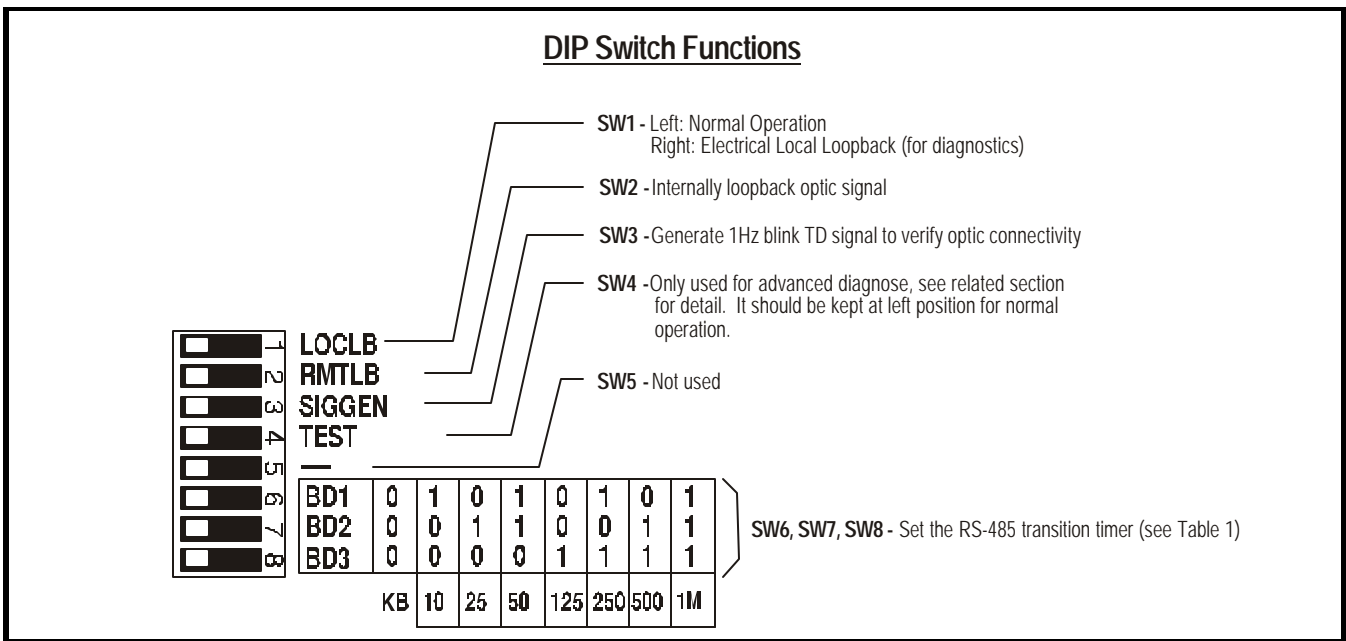

Figure 3. TC1540's DIP Switch Functions

LED Functions

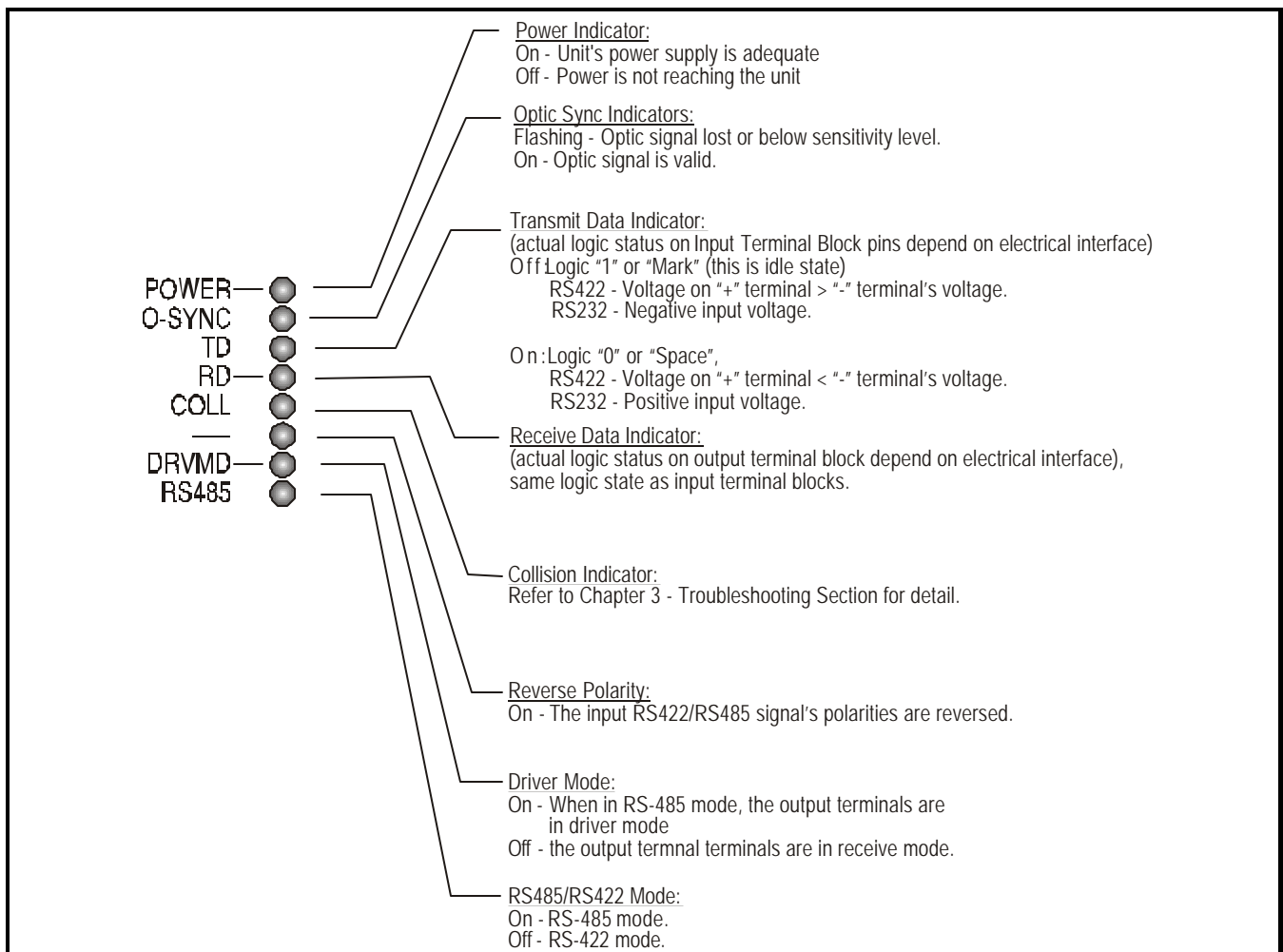

Figure 4. TC1540's LED Indicator Functions

Theory of 2 and 4-Wire RS-485 Operation

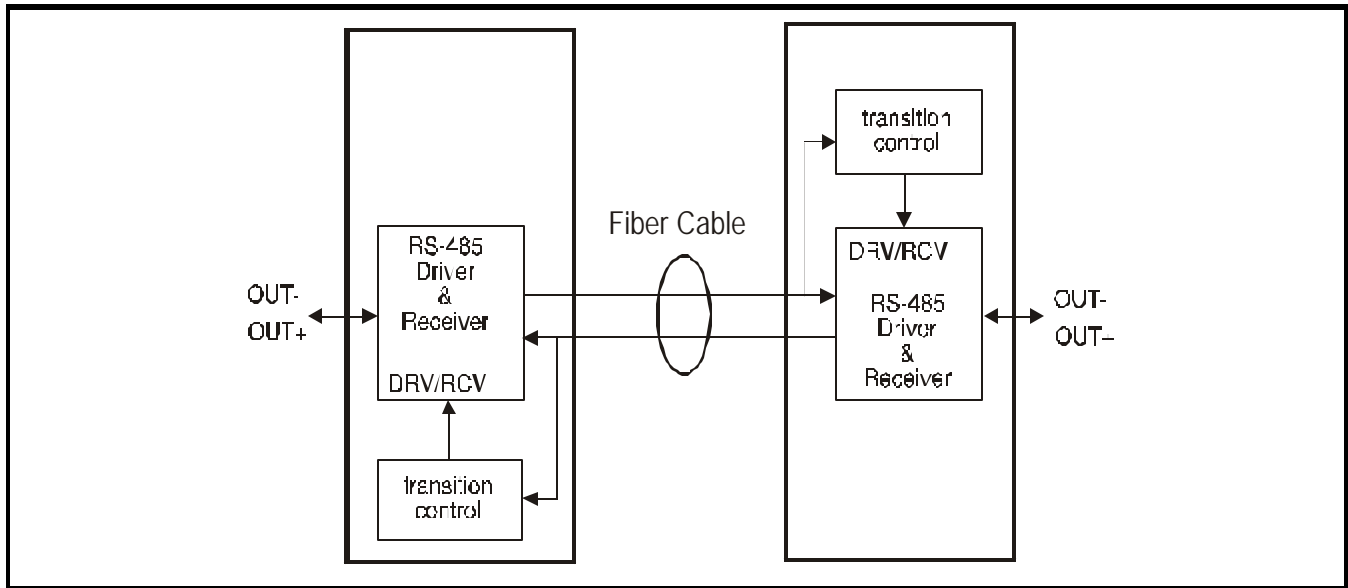

Figure 5. 2-Wire RS-485 Logic Diagram

Two-wire RS-485 is a half-duplex operation, which means transmit and receive operations take turns; they do not function concurrently. From the user's point-of-view, the channel is in receiving mode when no data is transmitted from the remote unit.

Four-wire RS-485 is a full-duplex operation, which means transmit and receive operations function concurrently. From the user's point-of-view, both channels are in the receiving or transmitting mode at all times.

The RS-485 Driver/Receiver transition time is determined by three DIP switches on the TC1540. The local unit's RS-485 transceiver changes to transmit (Tx) mode upon receiving the first bit of data from the remote unit. The transition time is the amount of time before the local unit's RS-485 transceiver will revert to the high-impedance receiver mode after the last bit is received from the remote unit. The RS-485 transition time should be set according to Table 1 on the following page.

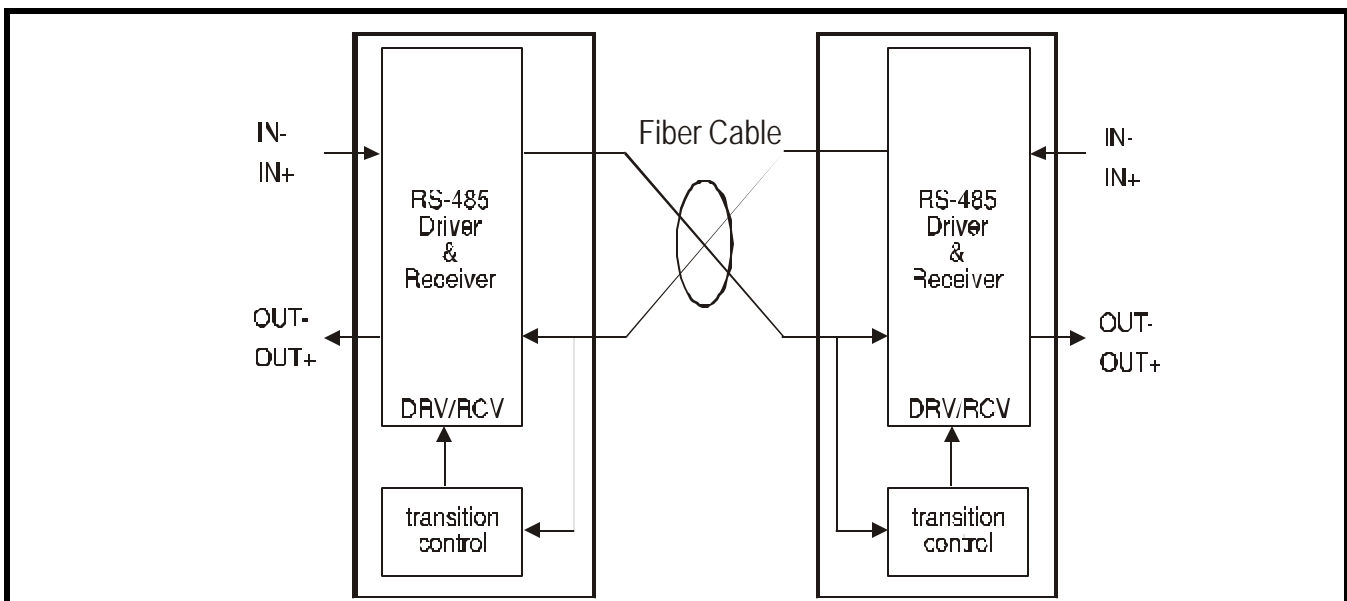

Figure 6. 4-Wire RS-485 Logic Diagram

RS-485 Transition Timer Setup

The following table provides setup information for configuring the front panel's DIP switches for an RS-485 application. To use the table, determine the baud rate of your application and set SW6, SW7, & SW8 accordingly. For example, if you know the async data baud rate of your application is 9600, then set SW6 to the Right; SW7 and SW8 to the Left (on each unit). You may also want to try the 25Kbps or 50Kbps settings for a 9600 baud rate as a test to make sure you have the correct data rate (sometimes the best results come from trial and error). For RS-232 and RS-422 interfaces, these three switches should be kept in the Left position.

	Baud Rate	10Kbps	25Kbps	50Kbps	100Kbps	250Kbps	500Kbps	1Mbps
	Transition Time	1msec	400 ms	200 ms	100 ms	40 ms	20 ms	4 ms
	4-wire RS-422	2-wire HS-485	2-wire HS-485	2-wire HS-485	2-wire HS-485	2-wire HS-485	2-wire HS-485	2-wire HS-485
SW-6	<input checked="" type="checkbox"/>	<input type="checkbox"/>	<input checked="" type="checkbox"/>	<input type="checkbox"/>	<input checked="" type="checkbox"/>	<input type="checkbox"/>	<input checked="" type="checkbox"/>	<input type="checkbox"/>
SW-7	<input checked="" type="checkbox"/>	<input checked="" type="checkbox"/>	<input type="checkbox"/>	<input checked="" type="checkbox"/>	<input checked="" type="checkbox"/>	<input checked="" type="checkbox"/>	<input type="checkbox"/>	<input checked="" type="checkbox"/>
SW-8	<input checked="" type="checkbox"/>	<input checked="" type="checkbox"/>	<input checked="" type="checkbox"/>	<input checked="" type="checkbox"/>	<input type="checkbox"/>	<input checked="" type="checkbox"/>	<input checked="" type="checkbox"/>	<input checked="" type="checkbox"/>

When SW6,7,8 are all at left side, the electrical interface is set for RS-422

Table 1. RS-485 Transition Timer Setup Table

RS-422 & RS-485 Termination Resistor

A termination resistor is usually necessary for RS-422 and RS-485 applications. Without proper termination, the error rate of data transmission may be high due to an "echo" effect on the electrical connection. With the addition of a termination resistor at the beginning or end of the electrical bus, this echo effect is greatly reduced. The termination resistors are 100 to 130 ohm resistors located inside the TC1540. Two jumpers, identified as board locations "W1" & "W5," control the termination resistance on each unit (installed by default). "W1" controls the resistance for the unit's receiver (IN), while "W5" controls the transmitter's (OUT) resistance. Proper line termination is required when TC1540 is placed at the end of RS-422/RS-485 bus. There is no termination resistor required for RS-232 applications.

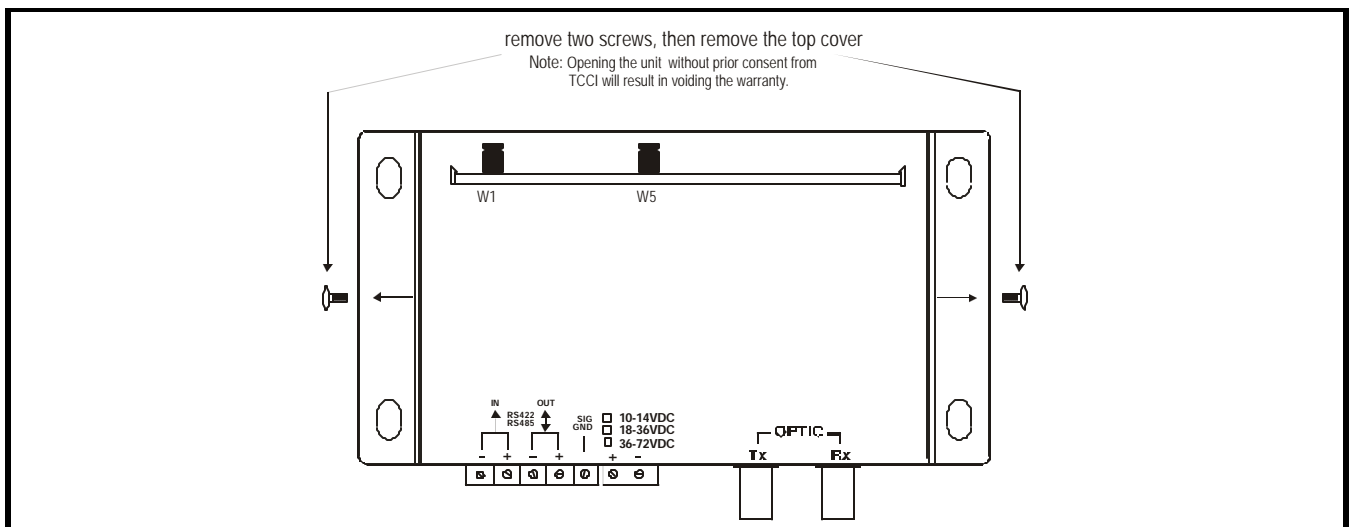

Figure 7. TC1540's Termination Resistor Locations

Pin Assignments and Connection

The removable terminal blocks on the TC1540 factory configured as DCE. The pin assignments for each type of interface are illustrated below. Pins IN(-) & IN(+) are inputs and Pins OUT(-) & OUT(+) are outputs (or input/output for 2-Wire RS-485).

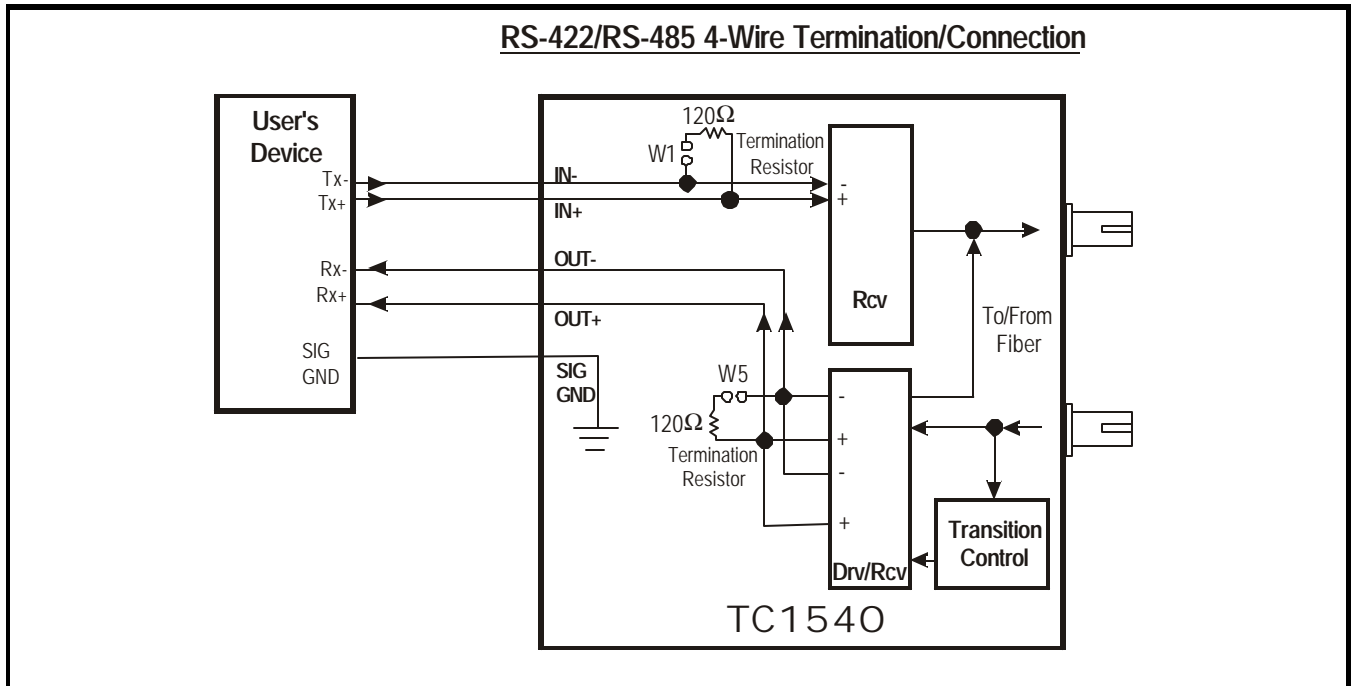
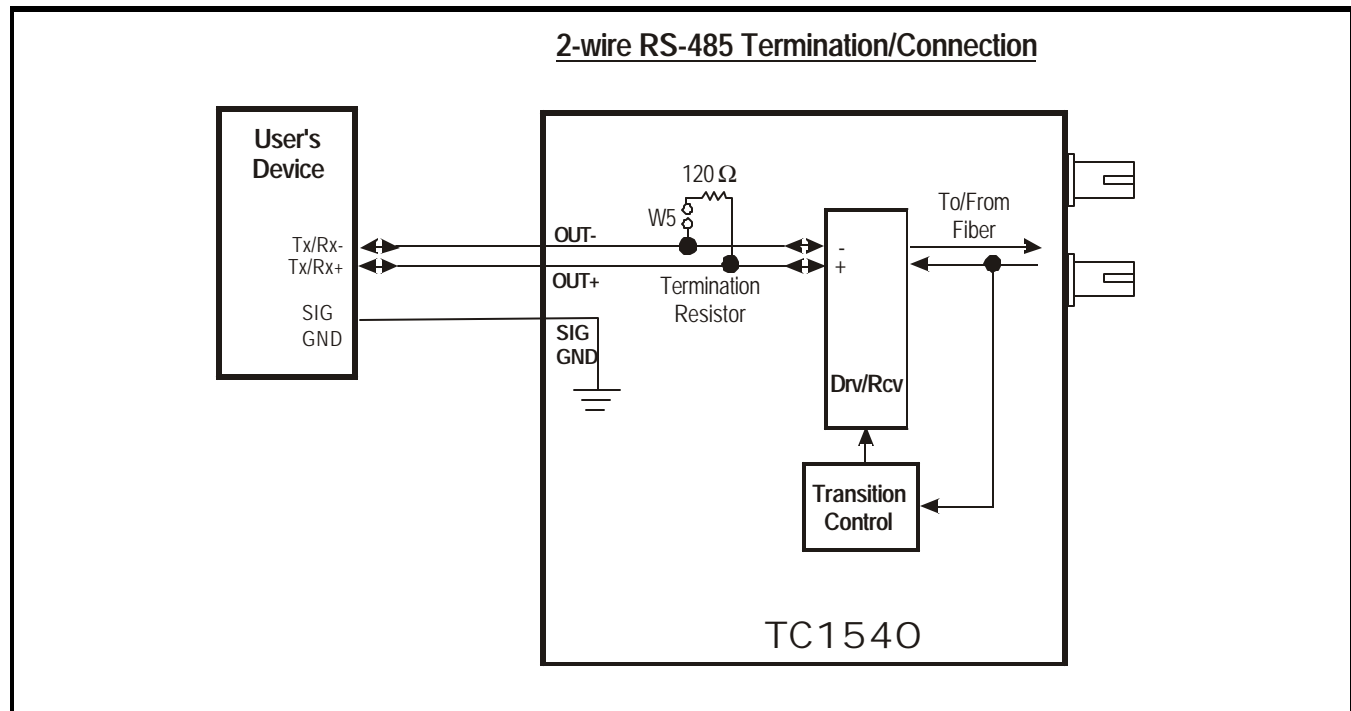
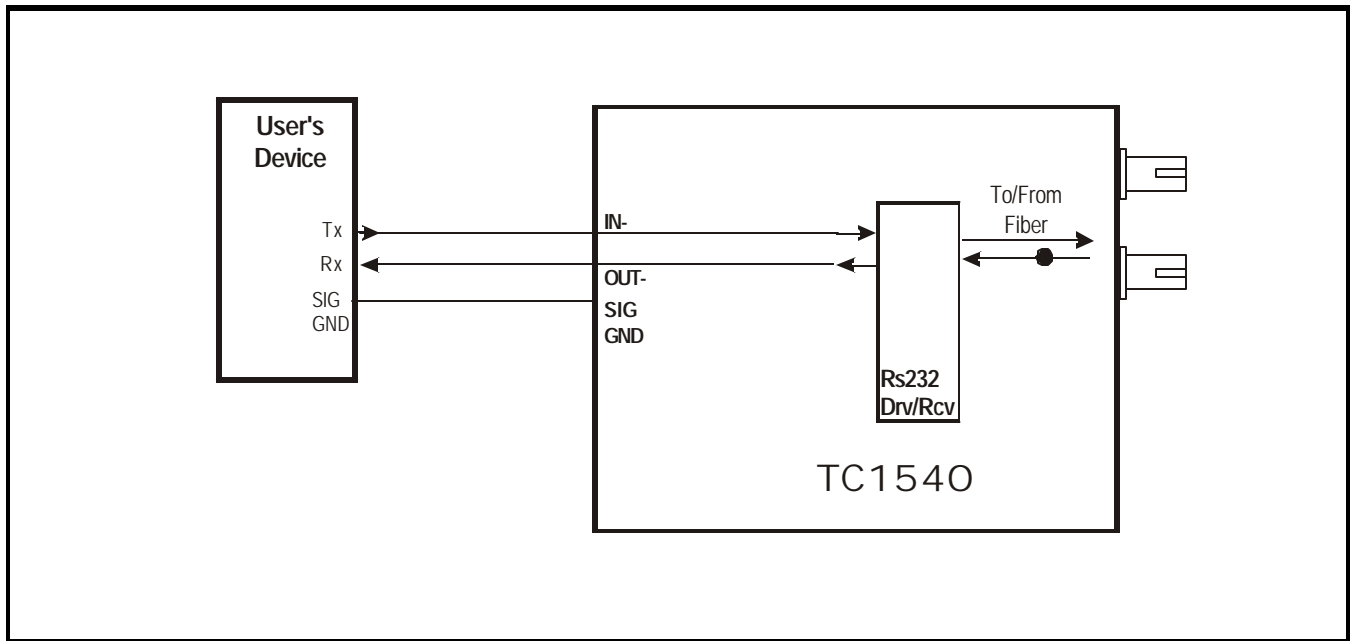

Figure 8. 4-wire RS-422/RS-485 Connection/Logic Diagram



Figures 9, 2-wire RS-485 Connection/Logic Diagram



Figures 10, 2-wire RS-232 Connection/Logic Diagram

Transmission Distances (typical)

The TC1540 is compatible with all popular sizes and types of fiber. Transmission distances up to 3km* are typical over Multimode fiber at 850nm and 4km* at 1310nm. Distances to 35m* are typical over Single Mode fiber at 1310nm.

Launch Power & Sensitivity

Transmitter:	LED/ELED; typical Launch Power -	-20dBm* (850nm/1310nm MM, @62.5/125µm) -16dBm* (1310nm Single Mode, @9/125µm)
Receiver:	PIN Diode; typical Sensitivity -	-36dBm* (850nm/1310nm MM, @62.5/125µm) -36dBm* (1310nm Single Mode, @9/125µm)

**Launch power, sensitivity and distance are listed for reference only. These numbers may vary.*

Power Supply

Typically, a 9V to 12V DC power supply @250mA is adequate for the TC1540. The power plug is a terminal block connector with positive & negative polarity indicated on the top panel of the unit. Alternate power sources are available as an option (see Chapter 5 - Specifications).

Chapter 2 - Installation

Unpacking the Unit

Before unpacking any equipment, inspect all shipping containers for evidence of external damage caused during transportation. The equipment should also be inspected for damage after it is removed from the container(s). Claims concerning shipping damage should be made directly to the pertinent shipping agencies. Any discrepancies should be reported immediately to the Customer Service Department at TC Communications, Inc.

Equipment Location

The TC1540 should be located in an area that provides adequate light, work space and ventilation. Avoid locating it next to any equipment that may produce electrical interference or strong magnetic fields, such as elevator shafts and heavy duty power supplies. As with any electronic equipment, keep the unit from excessive moisture, heat, vibration and freezing temperatures.

Installation Procedure Summary

The TC1540 is designed for quick and easy installation. Before installing, however, double-check the polarity at the DC power's terminal block connector.

- A. If power indicator is not on after power is connected then the polarity of DC power connections may be reversed. Reversed power polarity will not cause any damage to the unit.
- B. Connect fiber optic cables between the local & remote units as shown in Figure 12; the local unit's optic "Tx" connects to the remote unit's optic "Rx".
- C. Connect the local device's RS-232, RS-422 or RS-485 signal to the terminal blocks of TC1540. Observe that all the LED flashes (except "POWER" LED) for 2 to 3 second when power first is applied.
- D. Connect the remote device's RS-232, RS-422 or RS-485 signal to the DB25 connector on the rear panel of a second TC1540. Connect power to the unit. Observe that the "TD" LED flashes when an incoming signal is transmitted from that unit's local device. Verify that the "RD" LED on the remote TC1540 also flashes when an incoming signal is received from the remote unit.
- E. Run an Optic Loopback, Local Loopback and Remote Loopback Test (see pages 16, 17 & 18) for each kind of test.
- F. Verify System Integrity:

At each unit, check the "O-SYNC" indicator. The "O-SYNC" LED indicates the optic signal has been received and synchronized. If the optic cable is broken, the related "O-SYNC" (on the receiving side) will flash.

Verify and record the optical cable loss for each link in the application after installation is complete. This reading will both verify the integrity of the circuit and provide a benchmark for future troubleshooting efforts (see Chapter 3 - Troubleshooting).

Installation Example (for 2-wire RS-485 application)

Figure 11 depicts a typical 2-wire RS-485 application. The host controller polls the status of the remote RTU through a 2-wire RS-485 bus. Once the remote RTU receives the polling message, it answers with a response signal. The communication is half-duplex: the polling device and responding RTU take turns transmitting.

Electrical Interface: 2-wire RS-485
Data Rate: 9600 Baud (Async)
Optic Redundancy: Utilized
DIP Switch settings: SW1, SW2, SW3, SW4, SW5, SW7 and SW8 to Left; SW6 to Right (on both units)
LEDs to observe: Local & remote unit's "TxD" and "RxD" LEDs should flash in an alternating pattern (due to half-duplex communication)

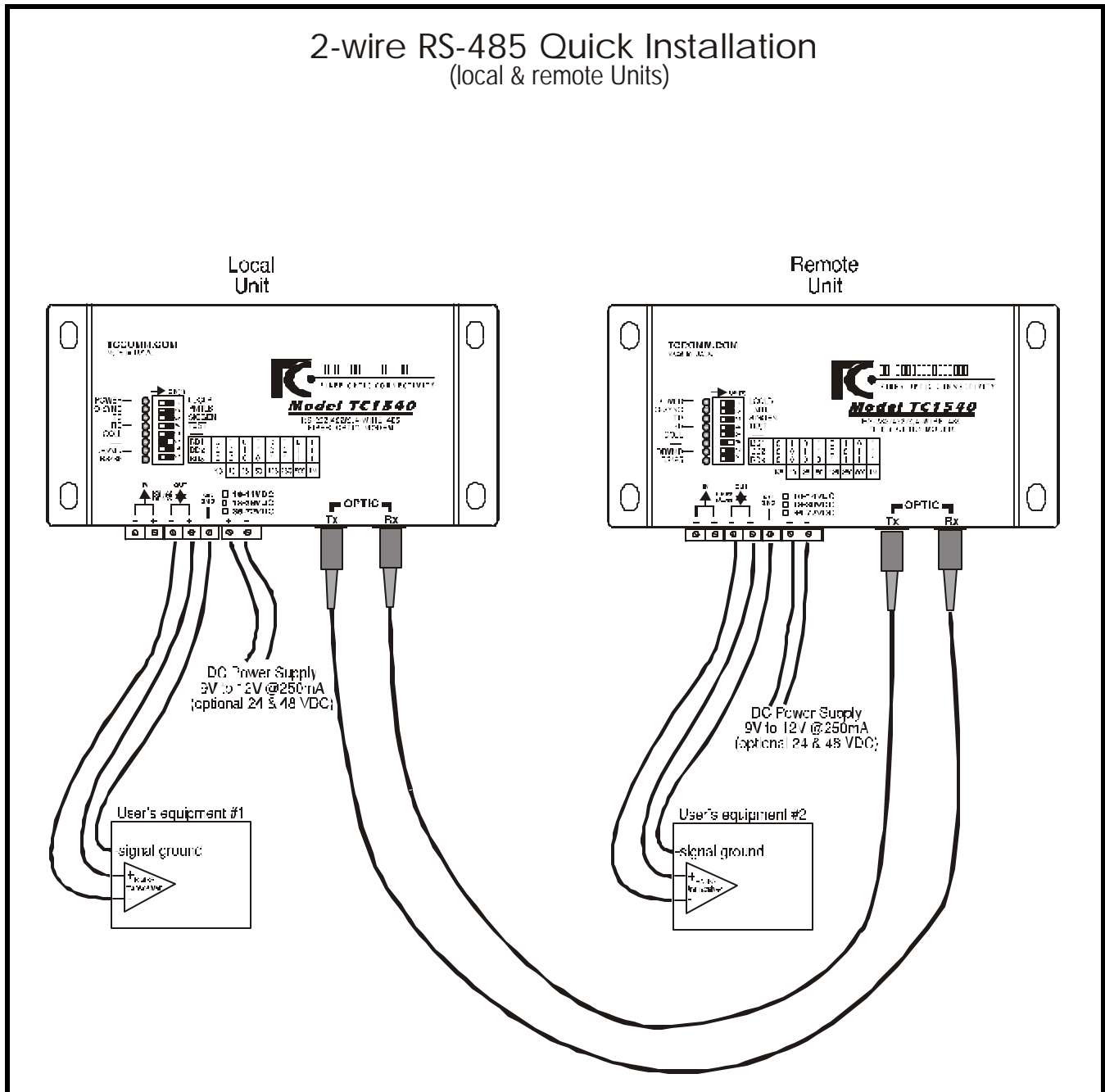

Figure 11. 2-Wire RS-485 Installation Diagram

4-wire RS-485 Quick Installation (local & remote Units)

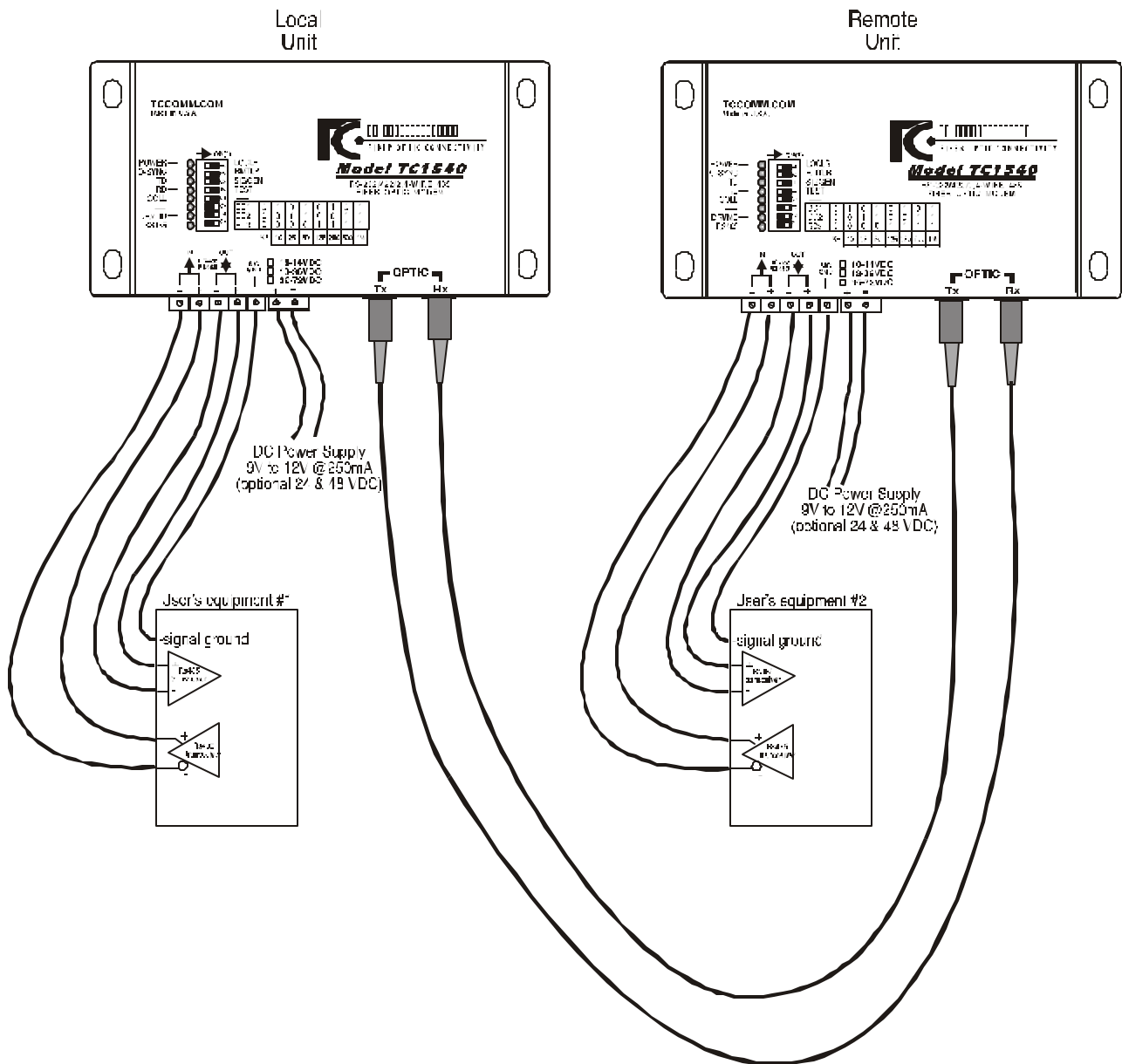

Figure 12. 4-Wire RS-485 Installation Diagram

Chapter 3 - Troubleshooting

General

Alarm conditions occur whenever an optical problem or "fault" condition is detected by the TC1540. Under normal operation, following LEDs should be lit

"POWER," "O-SYNC," "TD," and "RD."

Following LEDs may be "ON" or "OFF" depend on applications:

"COLL"- for trouble-shoot, not used. It should be off at all times.

"DRVMD"- turned on only when "OUT" terminal blocks are in "driver" mode.

"RS-485"- turned on when TC1540 is configured as RS-485 interface. (see DIP switch settings).

Power On LEDs Flash

When power first applied to TC1540, all the LEDs flash for two to three seconds.

Alarm Conditions

When alarm condition

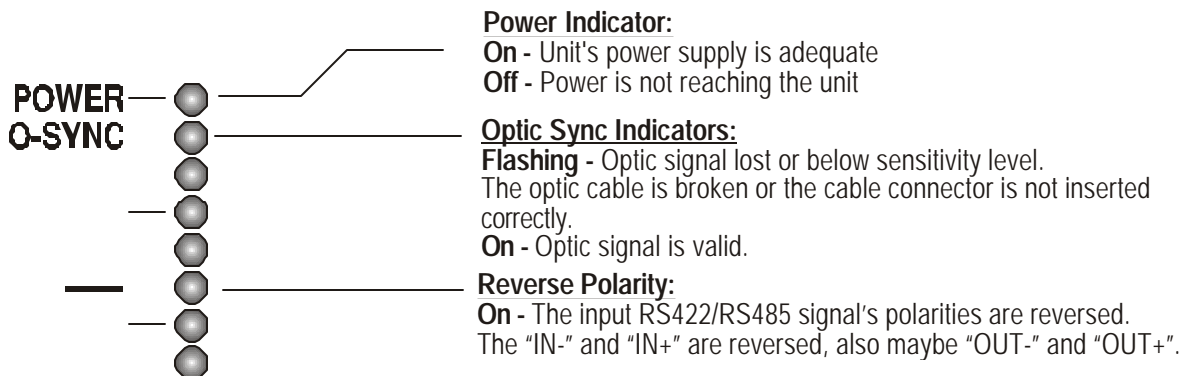

Optic Cable Types

Conventionally, fiber optic cable with yellow-colored insulation is used for Single Mode applications; gray or orange-colored insulated cable is for Multimode use. If Multimode cable is used in a Single Mode application, the test results could be erroneous and confusing.

Calculating the Fiber Optic Loss Budget

The fiber optic link and/or connectors are frequently the source of various problems. Check out the connectors and the integrity of the link first. Ideally, the link should be calibrated for total loss after the installation has been completed.

To calculate the loss budget:

Multimode 850nm	:	3 dB loss per km on 62.5/125µm cable*
Multimode 1310nm	:	2 dB loss per km on 62.5/125µm cable*
Single Mode 1310nm	:	0.5 dB loss per km on 9/125µm cable*
Single Mode 1550nm	:	0.4 dB loss per km on 9/125µm cable*

The TC1540 is designed with easy troubleshooting in mind. The LED indicators and DIP switches on the top cover will support various diagnostic functions. The first step in troubleshooting is to determine whether the problem is optical or electrical in nature. Figure 12 describes the steps required to isolate the problem. The tests related to each block are explained in Chapter 4 - Bench Tests.

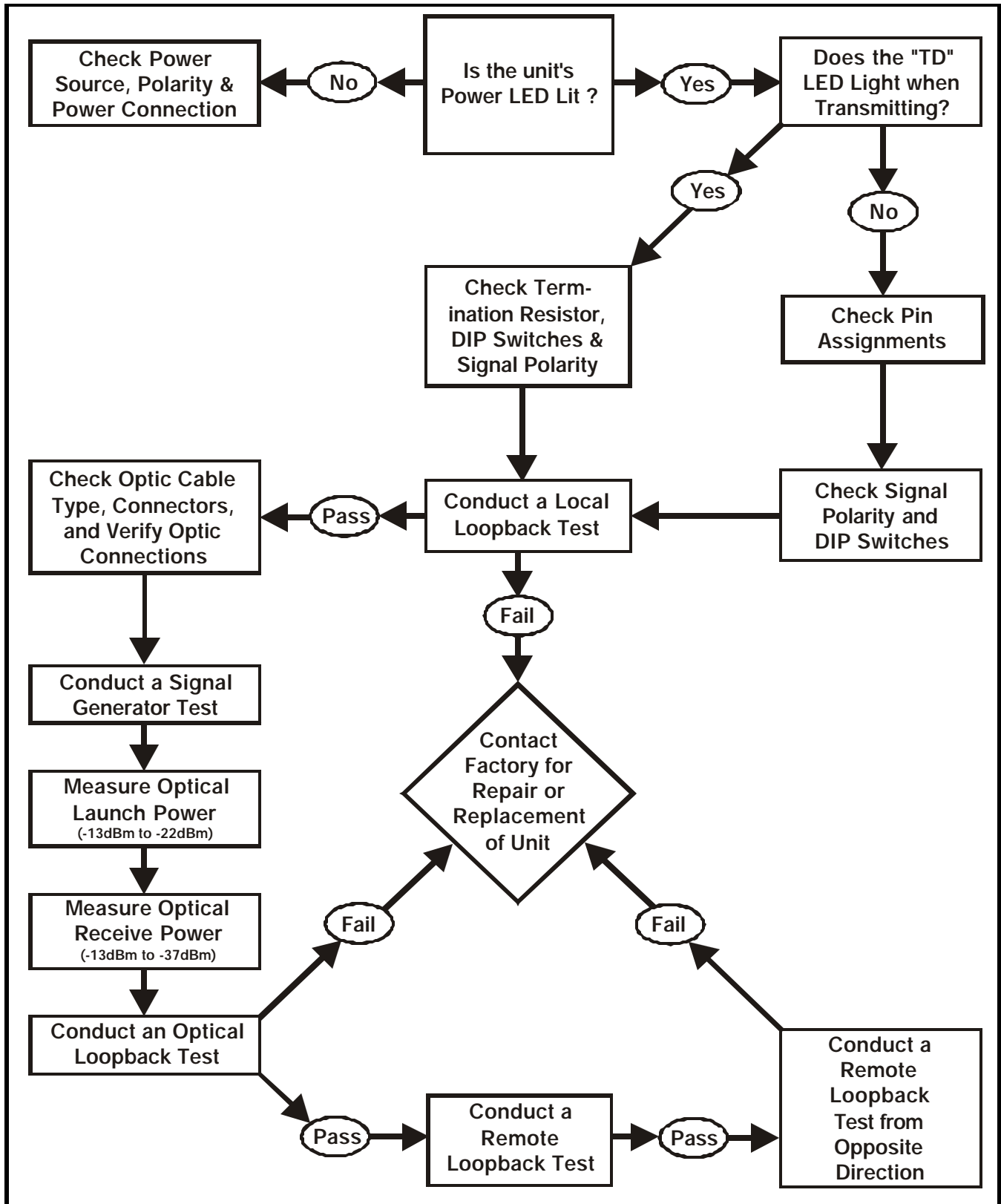

Figure 13. Troubleshooting Flowchart

Chapter 4 - Bench Tests

General

It is highly recommended to conduct bench tests before actual installation. Bench testing allows the user to become familiar with all the functions and features of the TC1540 in a controlled environment. Knowledge of the TC1540's functions and features will ease installation and troubleshooting efforts later on.

Testing Considerations

Most of the following bench tests specify a BERT (Bit Error Rate Tester) Test Set be used to perform the test. You may substitute the BERT with a PC (with a terminal emulation program that matches your devices RS-232, RS-422, or RS-485 interface) if necessary. For RS-485 interfaces, make sure the baud rate on the BERT or PC matches the baud rate DIP switch settings (SW6, SW7 and SW8) on the units tested.

The connection diagrams in this chapter are typical for all three types of interfaces; however, the DIP switch settings will vary depending on the type of interface, baud rate, and whether your unit is a single or dual optic model. The loopback tests can not be performed on a TC1540 unit with a 2-wire RS-485 interface due to its half-duplex operation; however, the Signal Generator feature can be used to facilitate troubleshooting. The DIP switch illustrations on each unit are typical for a dual optic TC1540 with a 4-wire RS-485 interface communicating at 9600 baud rate (Async).

Bench Test With Built-In Signal Generator

The TC1540 has a built-in signal generator to simulate a polling device's or RTU's incoming electrical signal. The built-in signal generator is a pulse signal indicated by a blinking LED. The flash rate is intentionally reduced for easy visual confirmation.

1. Set up the bench test as shown in Figure 14. At the local TC1540 unit, turn on the "SIGGEN" by sliding **SW3** to the Right. The "TD" LED on the local TC1540 should start blinking. Likewise, the "RD" LED on the remote TC1540 should also blink, indicating receipt of the local unit's simulated polling message.
2. At the remote TC1540, turn on the "SIG-GEN" by sliding **SW3** the Right. The "TD" LED should start blinking. Verify that the local unit's "RD" also blinks, indicating receipt of the remote unit's simulated response.

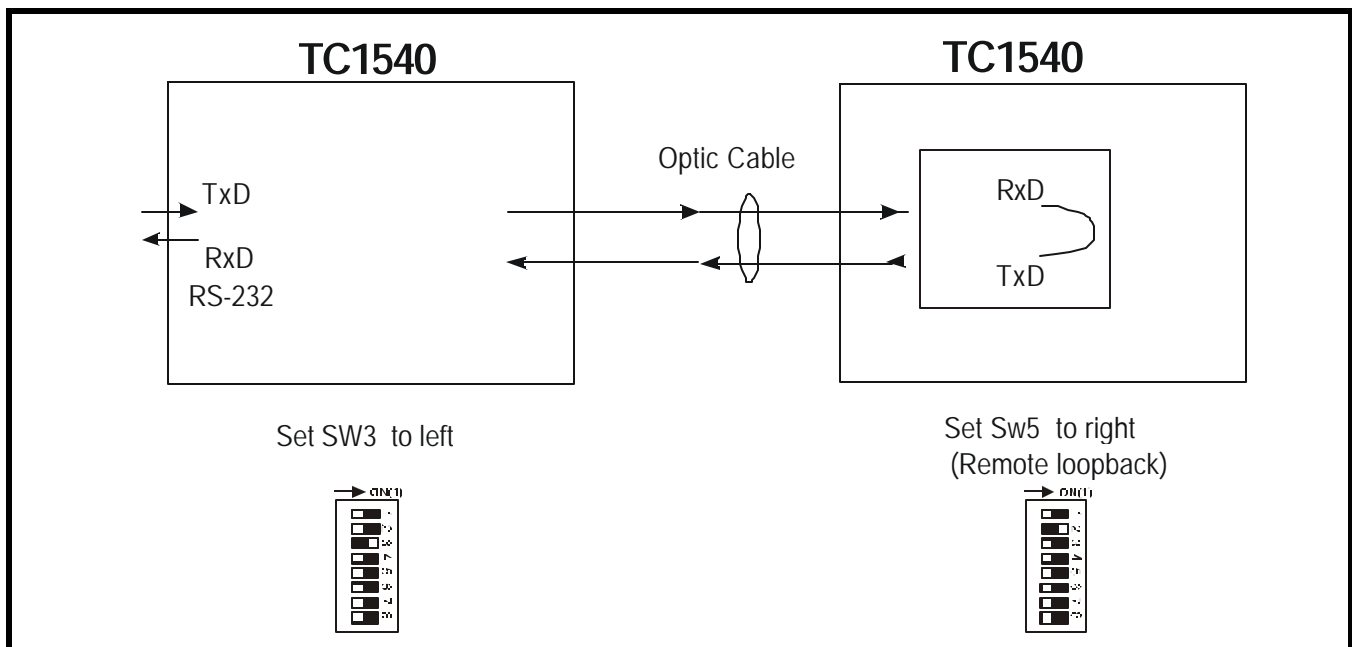

Figure 14. Signal Generator Bench Test Connection Diagram

Optic Loopback Bench Test

Purpose: This test loops the optic signal transmitted by the TC1540 back to the unit's receiver in order to test the transmit and receive capabilities of the unit without any other units attached.

Equipment

Requirements: One (1) Bit Error Rate Test (BERT) Set with appropriate interface module.

One (1) optical jumper cable (patch cord) with appropriate connectors.

Procedure:

Set up the bench test as shown in Figure 15. To test the "Tx" to "Rx" loop, connect an optic patch cord from optic "Tx" to optic "Rx." Set all the DIP switches to the Left position. Connect a BERT tester to the TC1540 according to Fig. 15. Set the tester up as a DTE device. The BERT tester should indicate a "SYNC" signal.

Remove the patch cord from "Tx" and "Rx", the "O-SYNC" LED on the TC1540 should flash.

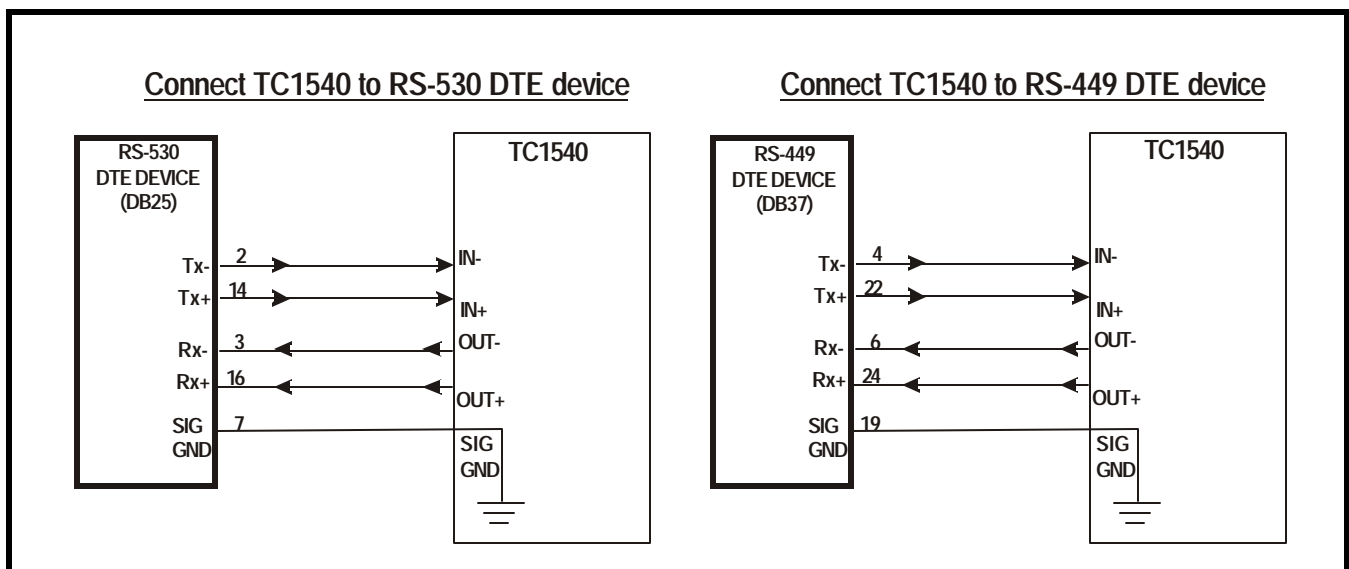

Figure 15. connect TC1540 to RS-530 or RS-449 Devices

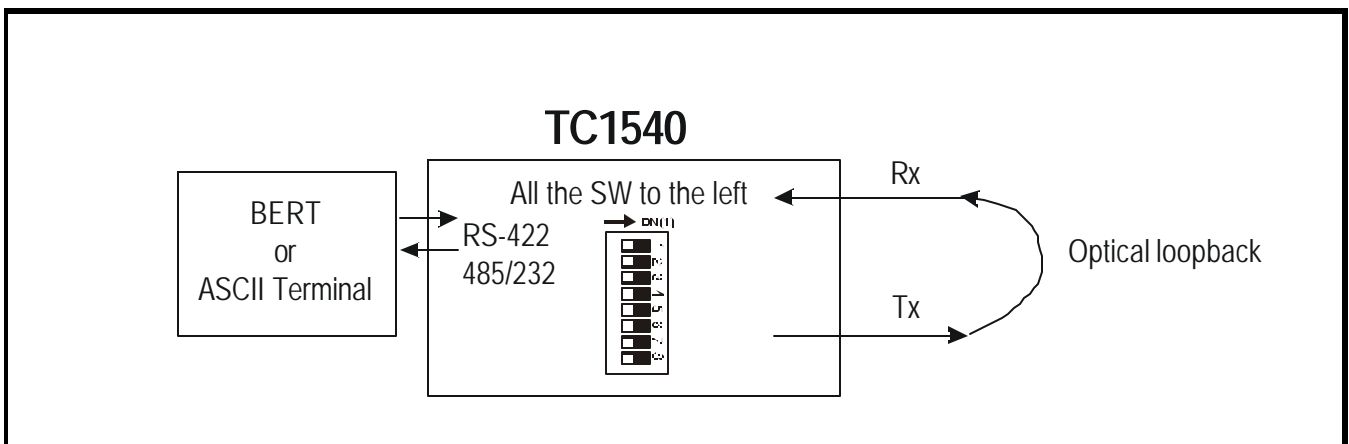

Figure 16. Optic Loopback Bench Test Connection Diagram

Local Electrical Loopback Bench Test

Purpose: This test loops the incoming RS-232, RS-422 or RS-485 electrical signal back to the output terminal blocks in order to verify the cable connections, the electrical interface driver, signal polarity (for RS-422/RS-485) and the receiver's Integrated Circuitry.

Equipment

Requirements: One (1) Bit Error Rate Test (BERT) Set with appropriate interface module.

Procedure:

Set up the bench test as shown in Figure 15. Set **SW1** (LOCLB) to the Right position. Connect a BERT tester to the IN(-) and IN(+) terminal blocks. Set the tester up as a DTE device if RS-530 or RS-449 interface is used. "TD" and "RD" LEDs should light on the TC1540, indicating the status of the looped signal. The BERT tester should indicate a "SYNC" signal. This test should be performed on each individual unit in the application.

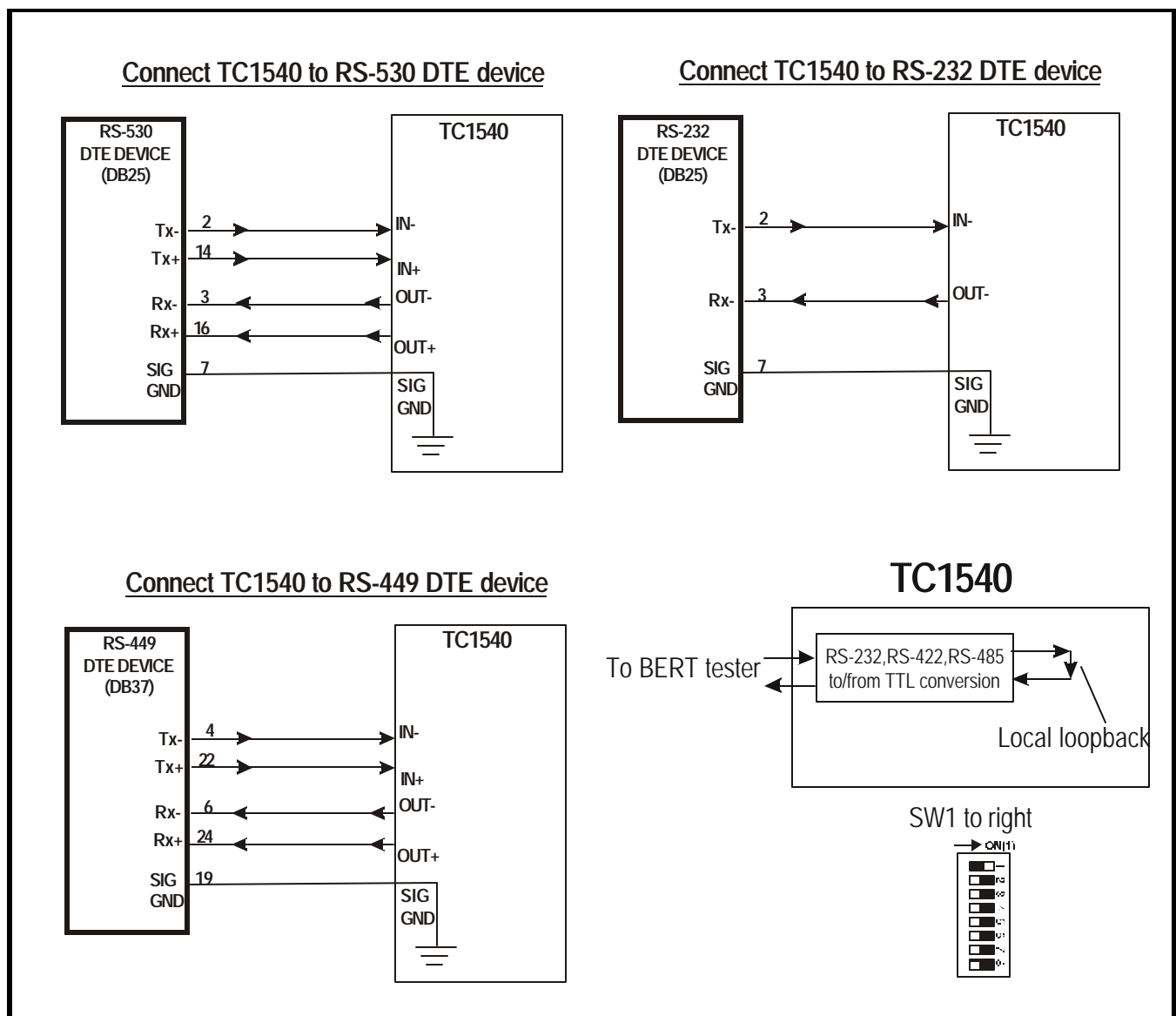

Figure 17. Local Loopback Bench Test Connection Diagram

Remote Loopback Bench Test

Purpose: This test loops the composite optical & electrical signal at the remote unit back to the local unit (via fiber) in order to test each unit's optic functions and LED indicators and to verify the integrity of the fiber optic link.

Equipment

Requirements: One (1) Bit Error Rate Test (BERT) Set with appropriate interface module.
At least two (2) optical jumper cables (patch cords) with appropriate connectors.

Procedure:

Set up the bench test as shown in Figure 16. On the remote unit, set **SW2** (RMTLB) to the Right position and connect a BERT tester to the local unit. Set the tester up as a DTE device (refer Fig. 15 for DTE device connection). The "TD" and "xD" LEDs (on both TC1540 units) should light, indicating the status of the looped signal. The BERT tester should indicate a "SYNC" signal. This test can be performed from either (or both) direction(s).

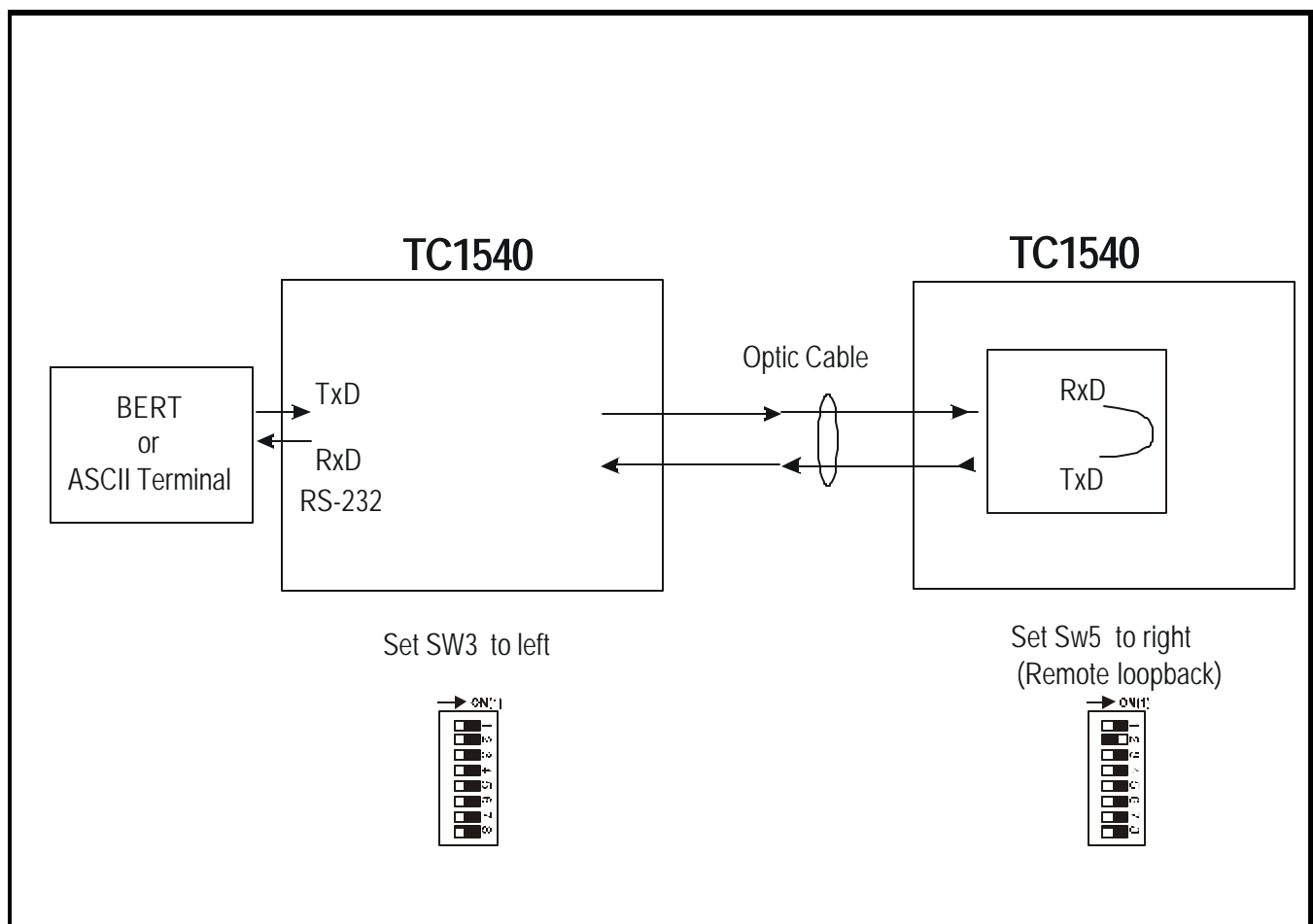

Figure 18. Remote Loopback Bench Test Connection Diagram

Chapter 5 - Specifications

Data Rates

Async up to 500 Kbps**

Optical

Transmitter LED/ELED
Receiver PIN Diode
Wavelength 850nm/1310nm Multimode
..... 1310nm Single Mode
Fiber Optic Connectors *ST (FC optional)
Loss Budget 15dB Multimode 850nm/1310nm @62.5/125µm
..... 20dB Single Mode 1310nm @9/125µm

Electrical

Connector Removable Terminal Blocks
Interface (DCE) RS-232, RS-422, or (2 or 4-wire) RS-485

System

Bit Error Rate 1 in 10⁹ or better
Visual Indicators POWER, O-SYNC, TD, RD, COLL, DRVMD, RS485,

Power Source

(standard) 12VDC@250mA
(optional) 24VDC@125mA(optional)
(optional) 48VDC@65mA

(optional) 115 or 230VAC with external power cube

Temperature

Operating -10°C to 50°C
Operating (extend temperature version TC1540T) -20°C to 70°C
Storage -40°C to 90°C
Humidity 95% non-condensing

Physical

Height (2.80 cm) 1.1"
Width (12.75 cm) 5.0"
Depth (8.0 cm) 3.15"
Weight (180 gm) 5.1 oz

**ST is a trademark of AT&T*

***Contact factory for higher data rate requirements*